









# Kar 350

Capacity 35,000 Kg / 77,162 Lbs  
Noiselevels 70dB (A)



## **OPERATION AND MAINTENANCE MANUAL** **Mechanical Levelling**

OMER NA Inc.  
2300 Speers Road, Oakville, ON. L6L 2X8  
Tel. 905-847-1198 Fax 905-891-1214

<b>1.</b>	 <b>General Information</b>	1 - 1
	1.1. Marketing Data	1 - 1
	1.2. Assistance	1 - 1
	1.3. Description of Personnel	1 - 2
<b>2.</b>	 <b>Description of The Machine</b>	2 - 1
	2.1. Technical Data	2 - 1
	2.2. Nomenclature	2 - 1
	2.3. Overall Dimensions	2 - 1
	2.4. Loading Conditions	2 - 1
<b>3.</b>	 <b>Safety</b>	3 - 1
	3.1. Expected Use	3 - 1
	3.2. General Safety Regulations	3 - 1
	3.3. Precaution	3 - 2
	3.4. Improper Use	3 - 1
	3.5. Safety Device Features	3 - 2
	3.6. Residual Risks	3 - 3
	3.7. Stickers and Plates	3 - 4
<b>4.</b>	 <b>Installations</b>	4 - 1
	4.1. Transport and Handling	4 - 1
	4.2. Place of Installations	4 - 3
	4.3. Connecting the Lift	4 - 4
	4.4. Connecting the Lift's Commands	4 - 4
	4.4.1. Hydraulic connections	4 - 4
	4.4.2. Pneumatic connections	4 - 6
	4.4.3. Electric connections	4 - 6
	4.5. Filling of The Circuit Master-Slave	4 - 8
	4.6. Lift Position	4 - 9
	4.7. Check	4 - 10
	4.8. Anchor Bolt Installation	4 - 11
	4.9. Checks Before Use	4 - 12
	4.10. Final Testing	4 - 13
<b>5.</b>	 <b>Use</b>	5 - 1
	5.1. Operational Commands	5 - 1
	5.2. Usage Advice	5 - 3
<b>6.</b>	 <b>Maintenance</b>	6 - 1
	6.1. Ordinary/Extraordinary Maintenance	6 - 1
	6.2. Table Adjustment Procedures	6 - 3
	6.2.1. Maximum Pressure valve calibration	6 - 3
	6.2.2. Photocell	6 - 4
	6.2.3. Velocity Fuse	6 - 5
	6.2.4. Platform levelling	6 - 6
	6.2.5. Unblocking safety locks	6 - 7
	6.2.6. Eliminating air from the volumetric circuit	6 - 7
	6.3. Safety Maneuvers	6 - 8
	6.4. Abnormal Operation	6 - 9
<b>7.</b>	<b>Accessories</b>	7 - 1

## 1. General Information

### 1.1. Marketing data

Table identification plate:

		<b>OMER. s.p.a.</b> BRAND CONTRY OF ORIGIN ITALY www.omerlift.com MANUFACTURED BY O.M.E.R. N.A. Inc 2300 SPEARS ROAD CAKVILLE ON L8L 2X8		AD0000
<b>KAR</b>				
SERIAL NR	RATINGS		MAX CAPACITY	Lb
YEAR OF MANUFACTURE		HP	MAX HYDRAULIC PRESSURE	psi
DATE		V	MAX AIR PRESSURE	psi
		3PH - 60 Hz.		
		A		

### 1.2 Assistance

OMER NA Inc. Phone: 877-799- LIFT (5438) Fax: 905-891-1214 Email: <a href="mailto:sales@KarLiftSolutions.com">sales@KarLiftSolutions.com</a> OMER NA Inc.

### **1.3 Description of Personnel**

#### **Terms and Definitions**

- **OPERATOR / SPECIALIZED TECHNICIAN**

the person(s) appointed to:

- Install
- set up
- adjust
- perform maintenance on
- clean
- repair
- transport the lift
- perform certain maintenance operations that require specific preparation and expertise in the mechanics, electrical, electronic, oil-hydraulic and pneumatic fields.

The specialized technician is aware of any risks present on the machine and the procedures to be followed to avoid damage to his / herself or others during such maintenance operations.

- **EXPOSED PERSON**

any person wholly or partly in a hazardous area.

- **HAZARDOUS OR RISKY AREA**

any area inside and / or close to a machine in whose presence an exposed person constitutes a risk for his / her health and safety.

- **USER**

anyone who buys or possesses the lift in any way (on loan, hire, lease, etc.), with the intention of using it as indicated by the manufacturer.

- **MAINTENANCE**

all activities, which shall be done to keep the system efficient and in good condition.

## 2. Description of the Machine

### Attention to:

- USER;
- OPERATOR / SPECIALIZED TECHNICIAN.

### 2.1. Technical Data

LIFT CAPACITY	KG	35,000	
	LB	77,162	
MOTOR POWER	KW	7,5	
	HP	10	
ELECTRIC POWER SUPPLY	V	220-240 / 440-480	
	Hz	60	
TOTAL CURRENT DRAW MAX	A	28.0 / 14.0	
PNEUMATIC POWER SUPPLY	bar	8	Filtered and lubricated
	psi	116	
MAXIMUM PRESSURE OF HYDRAULIC POWER SUPPLY	bar	250	
	psi	3626	
QUANTITY OF OIL	LT	40	
	G	10	
UPSTROKE/DOWNSTROKE TIME	S	70 / 80	
MIN/MAX OPERATING TEMPERATURE	C	-10 / +40	
SOUND EMISSION LEVEL	db(A)	< 80	

### 2.2 Nomenclature

MODELS LEGEND:

<b>N</b>	STANDALONE VERSION
<b>I</b>	RECESS-MOUNTED VERSION
<b>CA</b>	FRONT RECESS HOUSING ROTATING PLATES AND / OR GIVE DETECTOR PLATES

# 2. DESCRIPTION OF THE MACHINE

No	DESCRIPTION
1	Platform
2	Lower Leg
3	Upper Leg
4	Tension Rod
5	Hydraulic cylinder (main lift)
6	Base plate
7	Wheel Stop
8	Access Ramps
9	Electrical Controls
10	Hydraulic Pump
11	Flow Divider
12	Protective floor pipe covers
13	Ramp cover plate

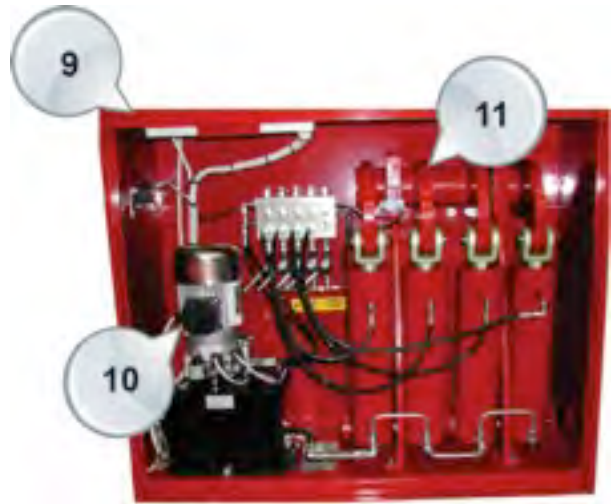

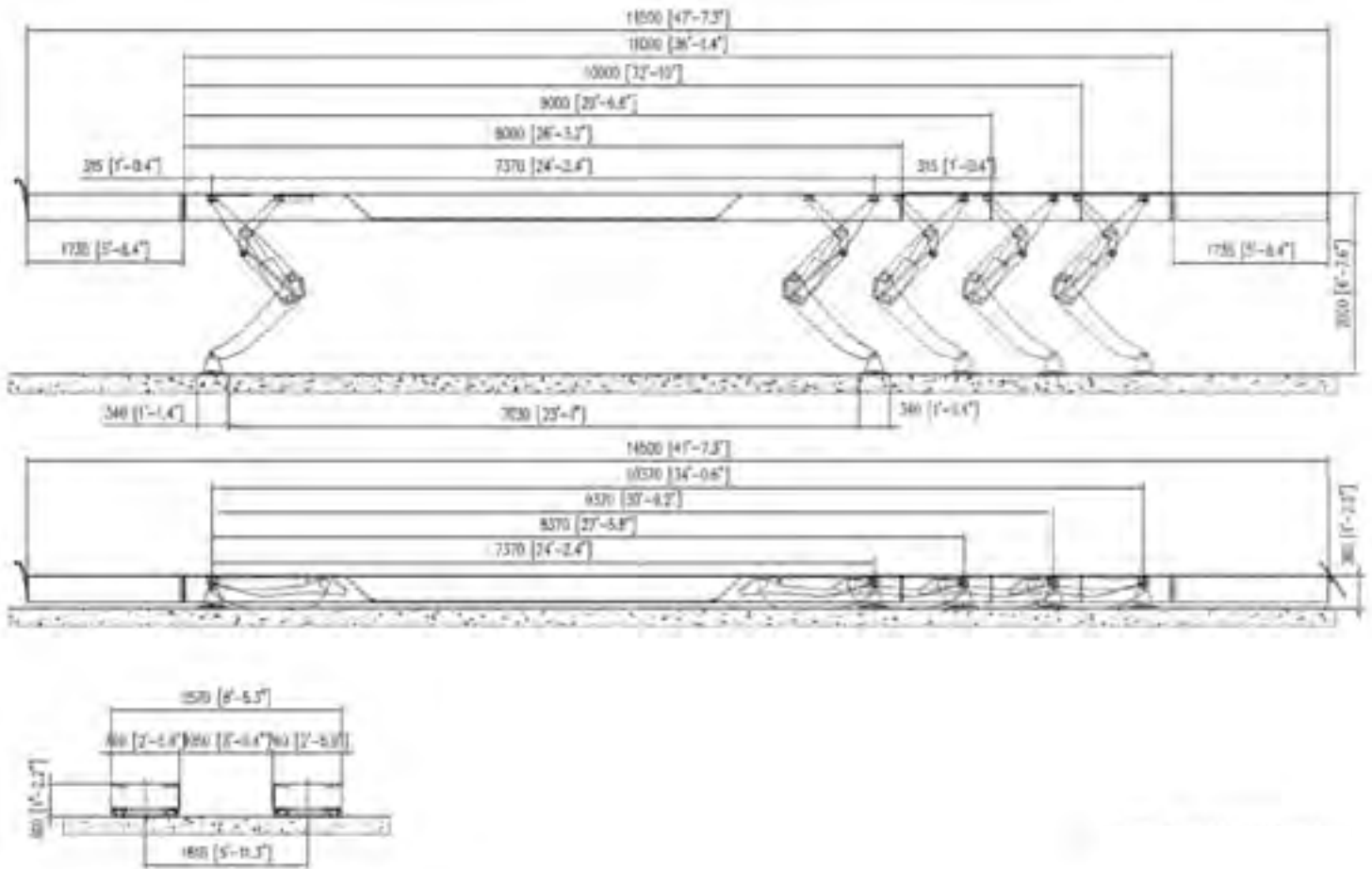

## 2. DESCRIPTION OF THE MACHINE

## 2.4 Loading Conditions





### 3. SAFETY

**Attention to:**

- USER
- OPERATOR / SPECIALIZED TECHNICIAN

#### 3.1. **Expected use**

The function of the vehicle lift is to lift motorized vehicles, which have the distribution of the loading according norms in force.

Only move the vehicle on the lift in the fully down position.

The accessories indicated in the relating chapter can be used.

#### 3.2. **General safety regulations**

For quick reference by operator, this manual must:

- be kept in a well known, easily accessible place
- be kept in good condition





Before proceeding with installation and use of the machine, the user must read the manual carefully, especially the safety rules.

The machine should be used by authorized, trained personnel only.





The user (owner and / or employee) must make sure that the installer has provided:





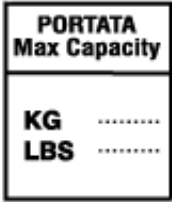

- all accessories
- the spares provided with the lift
- this use and maintenance manual

Use as described in this manual only.  
 Always use the accessories recommended by the manufacturer .  
 O.M.E.R. N.A. declines all responsibility for non-compliance with the directions given in this manual  
 The main safety rules are shown to the right.

	Read all instructions carefully
	Put the main switch to the zero position when the machines is not in use. Never pull the electric cable to remove the plug from the socket
	To reduce the risk of fires, avoid using the lift close to open drums of inflammable liquid (such as gas /oil) and/or in explosive environments.
	Makes sure the work area is adequately ventilated when using internal combustion engines
	Avoid contact between parts of the body and/or clothing and moving parts.

### 3.3 Precaution

	When loading the lift never exceed the capacity shown on the ID plate on the lift
	Never lift people.
	Any modifications to the lift must be authorized by the manufacturer
	The equipment must be used by specifically trained and authorized personnel only.
	Do not tamper with the lift's upstroke and downstroke

	<p>Always check the stability of the hoisted vehicle</p>
	<p>In case of “recess-mounted version” before carrying out the final lowering with bypass key, please ensure you that all personnel are clear of the lift.</p>
	<p>Do not use the lift in the event of poor operational or hazardous conditions</p>
	<p>Check the lift carefully after long periods of inactivity before putting it back into service</p>
	<p>The lift comes complete with an instruction manual warning labels designed to last. Ask the manufacturer for a replacements immediately if damaged or destroyed</p>
	<p>O.M.E.R NA. Inc declines responsibility for any inconvenience deriving from non-compliance with the instructions of use.</p>

### 3.4 *Improper use*

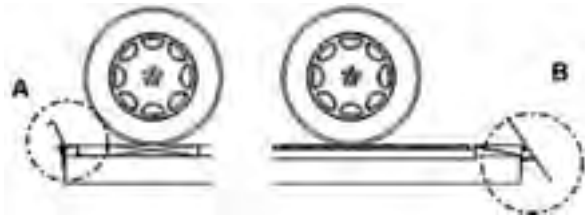
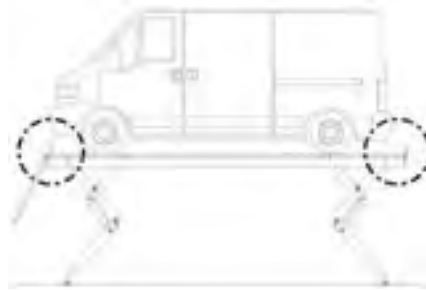

Never remove the stop (A) and the ramp overlay (B). They prevent the vehicle from coming off the platform.

Never lift vehicles using equipment other than that specified by the manufacturer



Never lift vehicles that are only partially on the lift

### 3.5 Safety Devices Features

<b><i>SAFETY DEVICE</i></b>	<b><i>COMPOSED OF</i></b>	<b><i>POSITION</i></b>	<b><i>IN THE EVENT OF...</i></b>	<b><i>EFFECT ON MAIN LIFT</i></b>
<b><i>Mechanical Anti-fall Device</i></b>	Rack jack	On each hydraulic cylinder of the lift	Leakage on the hydraulic circuit or breakage of a component	Accidental descent is blocked with a maximum displacement of a 4 inches
<b><i>The Guard Protection</i></b>	Limit switch and buzzer	On the master cylinders in the control unit	Descent on the last stretch	Platform descent stops at 6 inches off the ground To complete descent: • Turn the PEFT key switch Hold down the Down Button PD1 Final descent is confirmed by the buzzer
<b><i>Platform Alignment Control Device</i></b>	Photocell and reflectors	Each end of the platforms	Maximum misalignment of 2 inches between the platforms of the main or auxiliary lift	The lift stops moving
<b><i>Hydraulic Failure Device</i></b>	Velocity Fuse	On each hydraulic cylinder of the lift and on MASTER cylinder supply	Breakage of hoses	The valve blocks descent when the speed reaches a value preset by the Manufacturer
<b><i>Safety Device</i></b>	Microswitch	On each mechanical safety device	Mechanical safety position	Guarantees the insertion of the mechanical safety devices on the same tooth (geometrical position)
<b><i>Wheel Stop Devices</i></b>	Wheel Chock and Ramp Cover Plate	Front and rear in both lift platforms	_____	They prevent the vehicle from coming off the platforms
<b><i>Signals</i></b>	Stickers and plates	See paragraph: Stickers and plates	_____	Draw attention to risks and precautions for use

### 3.6 *Residual risks*

HAZARD	WHO	CONDITION	RISK
PIPE BREAKING	Maintenance Technician	MAINTENANCE	Contact with high pressure oil on rupture
ELECTRIC SHOCK	Maintenance Technician	MAINTENANCE	Contact with live components
PERSONAL INJURED	Maintenance Technician	MAINTENANCE	Shearing of hands and feet while lift is in movement

### 3.7. *Stickers and plates*

The labels must be readable and permanently attached to the equipment. The labels that will be furnished with equipment, together with their relevant positions, listed below

No	Plate description	
1	Control panel identification	
2	Risk of electric shock	
3	Risk of explosion	
4	Risk of Fire	
5	Fuses indication	
6	Air attachment	
7	Load distribution	
8	Serial number plate	
9	GOLD LABEL CODE	LIFT
		CONTROL UNIT
10	Operating time	
11	Safety instruction (GB)	
12	Warning	
13	Grounding	
14	Duty cycle time	
15	Logo KAR 350	
16	Logo Omer	
17	MAX CAPACITY	
18	Do not stay near the lift in movement	
19	Safety Instructions	

# LIFT

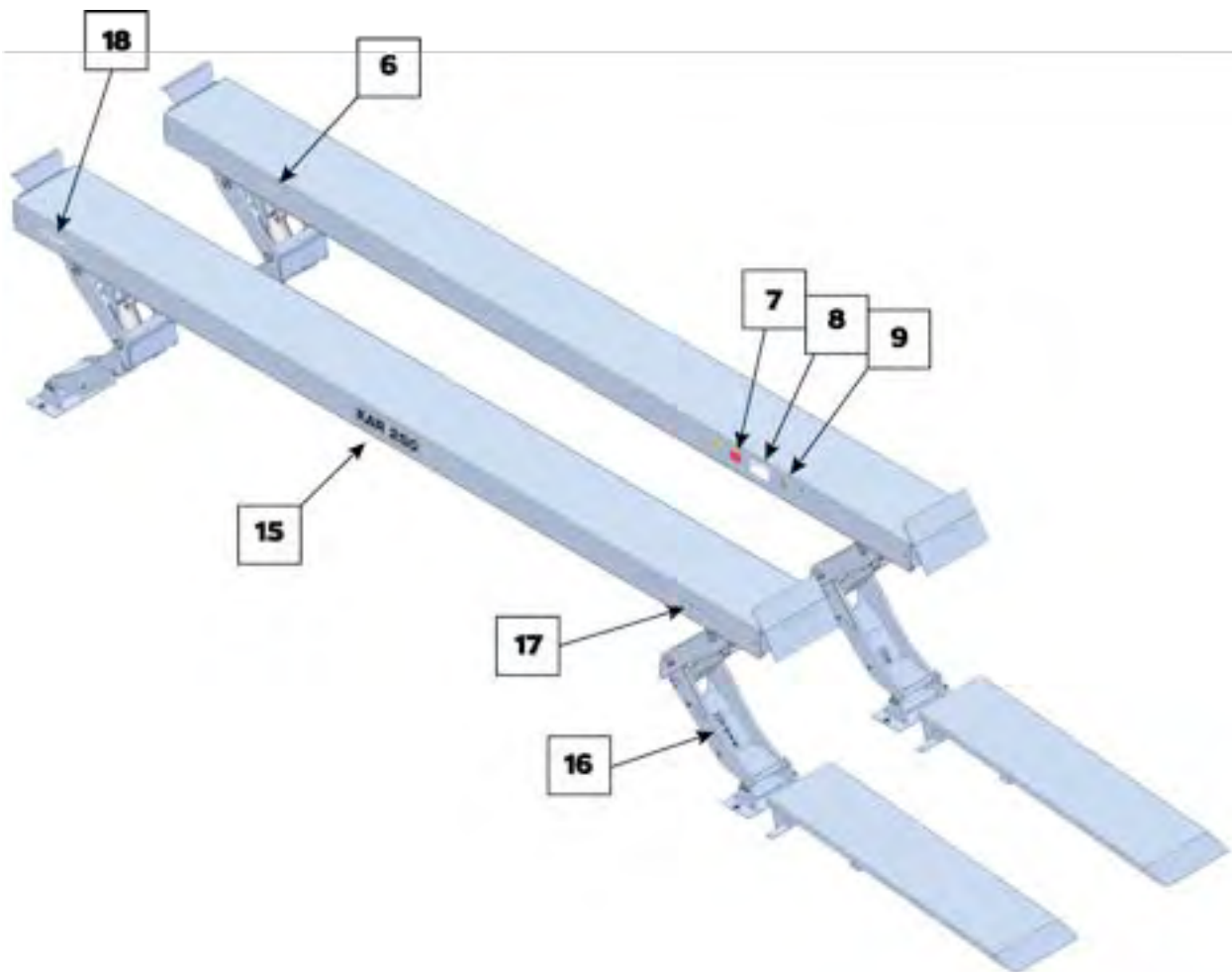



# CONTROL UNIT

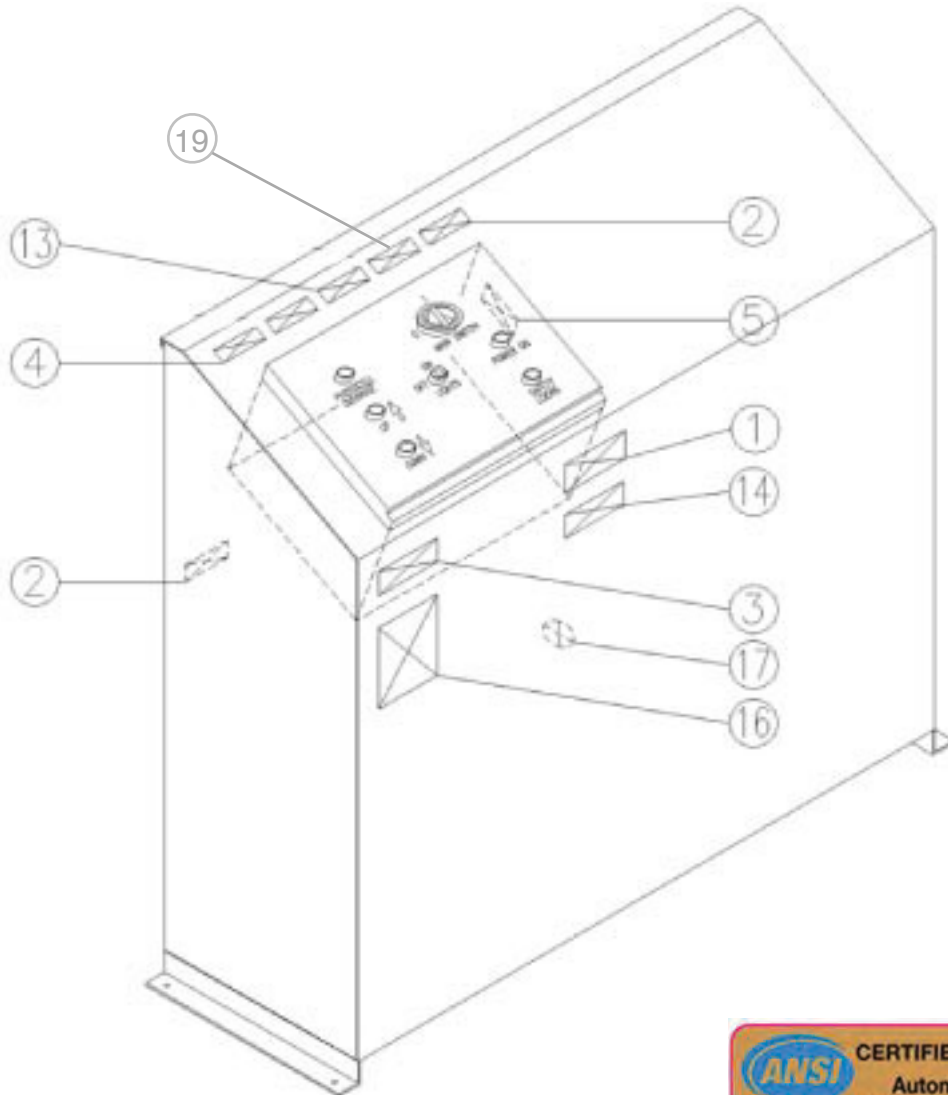

**ANSI** CERTIFIED AUTOMOTIVE LIFT  
 Automotive Lift Institute  
 ANSI Accredited Certification Program  
 Accreditation Number 0554

Validated  
**AL**  
 Certified  
 BY ETL

XXXXXXXXXX

Verified and Administered by  
 Intertek Testing Services NA Inc.  
**TO THE PROVISIONS OF  
 ANSI/ALI ALCTV-2006**  
 ETL LISTED

SAFETY STANDARD  
 FOR GARAGE EQUIPMENT





CONFORMS TO ANSI/U.L. STD 201

MOTOR OPERATED APPLIANCES  
 (HOUSEHOLD & COMMERCIAL)

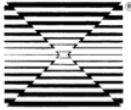

**ETL** US CERTIFIED TO CAN/CSA STD C22.2 NO.68  
 C XXXXXXXXXXXX

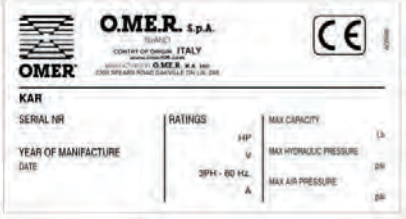
XXXXXXXXXX Intertek Testing Services NA Inc.  
 CORTLAND, NEW YORK 13045

<p><b>LABEL 1</b></p>	 <p>IDENTIFICATION: _____          CATALOG PART NR. _____          ELECT. RATINGS _____          MANUFACTURED ON _____</p> <p><b>OMER</b>          Tel. 041.5700303 - Fax 041.5700273          OMER SPA - ITALY</p>
<p><b>LABEL 2</b></p>	<p><b>“CAUTION: RISK OF ELECTRICAL SHOCK,          DO NOT REMOVE COVER.          NO USER-SERVICEABLE PARTS INSIDE.          REFER SERVICING TO QUALIFIED          PERSONNEL.”</b></p> <p style="text-align: right;"><small>AD00000488</small></p>
<p><b>LABEL 3</b></p>	<p><b>“WARNING: RISK OF EXPLOSION.          THIS EQUIPMENT HAS INTERNAL ARCING OF SPARKING          PARTS WHICH SHOULD NOT BE EXPOSED TO FLAMMABLE          VAPORS. IT SHOULD NOT BE LOCATED IN A RECESSED AREA          OR BELOW FLOOR LEVEL.”</b></p> <p style="text-align: right;"><small>AD00000489</small></p>
<p><b>LABEL 4</b></p>	<p><b>“CAUTION: FOR CONTINUED PROTECTION AGAINST RISK OF          FIRE, REPLACE ONLY WITH THE SAME TYPE .....          A, ..... V FUSE.          REFER SERVICING TO QUALIFIED PERSONNEL.”</b></p> <p style="text-align: right;"><small>AD00000489</small></p>
<p><b>LABEL 5</b></p>	<p><b>“IF CONNECTED TO A CIRCUIT          PROTECTED BY FUSES, USE TIME-DELAY          FUSES WITH EQUIPMENT.”</b></p> <p style="text-align: right;"><small>AD00000481</small></p>
	<p><b>“SI CONNECTÉ À UN CIRCUIT          PROTÉGÉ PAR DES FUSIBLES          UTILISER DES FUSIBLES À UNE          ACTION DIFFÉRÉE MARQUÉS D.”</b></p> <p style="text-align: right;"><small>AD00000481</small></p>

<p><b>LABEL 6</b></p>																
<p><b>LABEL 7</b></p>																
<p><b>LABEL 8</b></p>	 <table border="1" data-bbox="979 1056 1203 1150"> <thead> <tr> <th colspan="2">RATINGS</th> <th>MAX CAPACITY</th> </tr> </thead> <tbody> <tr> <td>HP</td> <td></td> <td>13</td> </tr> <tr> <td>V</td> <td></td> <td>20</td> </tr> <tr> <td>3PH - 60 HZ</td> <td></td> <td>20</td> </tr> <tr> <td>A</td> <td></td> <td>20</td> </tr> </tbody> </table>	RATINGS		MAX CAPACITY	HP		13	V		20	3PH - 60 HZ		20	A		20
RATINGS		MAX CAPACITY														
HP		13														
V		20														
3PH - 60 HZ		20														
A		20														
<p><b>LABEL 9</b></p>																
<p><b>LABEL 10</b></p>																

<p><b>LABEL 11</b></p>	
<p><b>LABEL 12</b></p>	<p><b>Automotive Lift Institute, Inc. WL200 Series Label Kit</b></p> <p>The messages and pictographs shown are generic in nature and are meant to generally represent hazards common to all automotive lifts regardless of specific style.</p> <p>Funding for the development and validation of these labels was provided by the Automotive Lift Institute, PO Box 85 Cortland, NY 13045.</p> <p>Replacement label sets may be obtained from the original lift manufacturer and ALI's member companies. They are protected by copyright.</p> <p>www.autolift.org ©1982 by ALI, Inc. ALI/WLSIAO1</p> <p>The messages and pictographs shown are generic in nature and are meant to generally represent hazards common to all automotive lifts regardless of specific style.</p> <p>Funding for the development and validation of these labels was provided by the Automotive Lift Institute, PO Box 85 Cortland, NY 13045.</p> <p>Replacement label sets may be obtained from the original lift manufacturer and ALI's member companies. They are protected by copyright.</p> <p>www.autolift.org ©1982 by ALI, Inc. ALI/WLSIAO1</p>
<p><b>LABEL 13</b></p>	

<p><b>LABEL 14</b></p>							
<p><b>LABEL 15</b></p>							
<p><b>LABEL 16</b></p>							
<p><b>LABEL 17</b></p>							
<table border="1"> <tr> <td data-bbox="251 1031 565 1157"> <p><b>PORTATA MAX. PORTEE MAX. MAX. TRAGKRAFT</b></p> </td> <td data-bbox="667 1031 980 1157"> <p><b>MAX. CAPACITY CARGA MAX. CAPACIDADE MÁX.</b></p> </td> <td data-bbox="1117 1031 1344 1157"> <p><b>KG 35000 LBS 77000</b></p> </td> </tr> </table>		<p><b>PORTATA MAX. PORTEE MAX. MAX. TRAGKRAFT</b></p>	<p><b>MAX. CAPACITY CARGA MAX. CAPACIDADE MÁX.</b></p>	<p><b>KG 35000 LBS 77000</b></p>			
<p><b>PORTATA MAX. PORTEE MAX. MAX. TRAGKRAFT</b></p>	<p><b>MAX. CAPACITY CARGA MAX. CAPACIDADE MÁX.</b></p>	<p><b>KG 35000 LBS 77000</b></p>					
<p><b>LABEL 18</b></p>							
<table border="1"> <tr> <td data-bbox="316 1270 483 1388"> <p><b>VIETATO SOSTARE NELLE VICINANZE DEL SOLLEVATORE IN MOVIMENTO</b></p> </td> <td data-bbox="488 1270 646 1388"> <p><b>DEFENSE DE STATIONNER EN PROXIMITE DU PONT EN MOUVEMENT</b></p> </td> <td data-bbox="651 1270 808 1388"> <p><b>ES IST VERBOTTEN IN DE NÄHE DER BÜHNE WÄHREND DES BETRIEBES ZU BLEIBEN</b></p> </td> <td data-bbox="813 1270 971 1388"> <p><b>DO NOT STAY NEAR THE LIFT IN MOVEMENT</b></p> </td> <td data-bbox="976 1270 1133 1388"> <p><b>PROHIBIDO SITUARSE BAJO EL ELEVADOR CUANDO ESTA EN MOVIMIENTO</b></p> </td> <td data-bbox="1138 1270 1295 1388"> <p><b>PROIBIDO PERMANECER DEBAJO DO ELEVADOR QUANDO ESTE ESTA EM MOVIMENTO</b></p> </td> </tr> </table>		<p><b>VIETATO SOSTARE NELLE VICINANZE DEL SOLLEVATORE IN MOVIMENTO</b></p>	<p><b>DEFENSE DE STATIONNER EN PROXIMITE DU PONT EN MOUVEMENT</b></p>	<p><b>ES IST VERBOTTEN IN DE NÄHE DER BÜHNE WÄHREND DES BETRIEBES ZU BLEIBEN</b></p>	<p><b>DO NOT STAY NEAR THE LIFT IN MOVEMENT</b></p>	<p><b>PROHIBIDO SITUARSE BAJO EL ELEVADOR CUANDO ESTA EN MOVIMIENTO</b></p>	<p><b>PROIBIDO PERMANECER DEBAJO DO ELEVADOR QUANDO ESTE ESTA EM MOVIMENTO</b></p>
<p><b>VIETATO SOSTARE NELLE VICINANZE DEL SOLLEVATORE IN MOVIMENTO</b></p>	<p><b>DEFENSE DE STATIONNER EN PROXIMITE DU PONT EN MOUVEMENT</b></p>	<p><b>ES IST VERBOTTEN IN DE NÄHE DER BÜHNE WÄHREND DES BETRIEBES ZU BLEIBEN</b></p>	<p><b>DO NOT STAY NEAR THE LIFT IN MOVEMENT</b></p>	<p><b>PROHIBIDO SITUARSE BAJO EL ELEVADOR CUANDO ESTA EN MOVIMIENTO</b></p>	<p><b>PROIBIDO PERMANECER DEBAJO DO ELEVADOR QUANDO ESTE ESTA EM MOVIMENTO</b></p>		
<p><b>LABEL 19</b></p>	<table border="1"> <tr> <td data-bbox="641 1444 1365 1583"> <p><b>DO NOT USE BELOW GARAGE FLOOR OR GRADE LEVEL</b></p> </td> </tr> <tr> <td data-bbox="641 1640 1365 1787"> <p><b>NE PAS UTILISER À UN NIVEAU INFÉRIEUR À CELUI DU PLANCHER DU GARAGE OU DU SOL</b></p> </td> </tr> </table>	<p><b>DO NOT USE BELOW GARAGE FLOOR OR GRADE LEVEL</b></p>	<p><b>NE PAS UTILISER À UN NIVEAU INFÉRIEUR À CELUI DU PLANCHER DU GARAGE OU DU SOL</b></p>				
<p><b>DO NOT USE BELOW GARAGE FLOOR OR GRADE LEVEL</b></p>							
<p><b>NE PAS UTILISER À UN NIVEAU INFÉRIEUR À CELUI DU PLANCHER DU GARAGE OU DU SOL</b></p>							

#### 4. Installation

Attention to:

- OPERATOR / SPECIALIZED TECHNICIAN

##### 4.1. Transport and handling

The packaged lift must only be transported using crane or fork truck with a greater capacity than the lift to be handled.

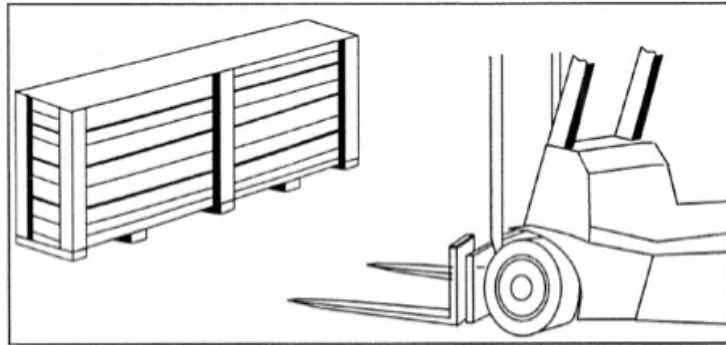

The equipment is wrapped in bubble pack to protect the components. Wooden crates or pallets are used in special cases.

PROCEED AS FOLLOWS:

- protect the electric control panel from exposure to the elements
- protect against blows and do not use the electronic control panel for hoisting
- protect the corner and ends of the piece to be transported with suitable material (bubble pack - cardboard)
- harness using dedicated straps

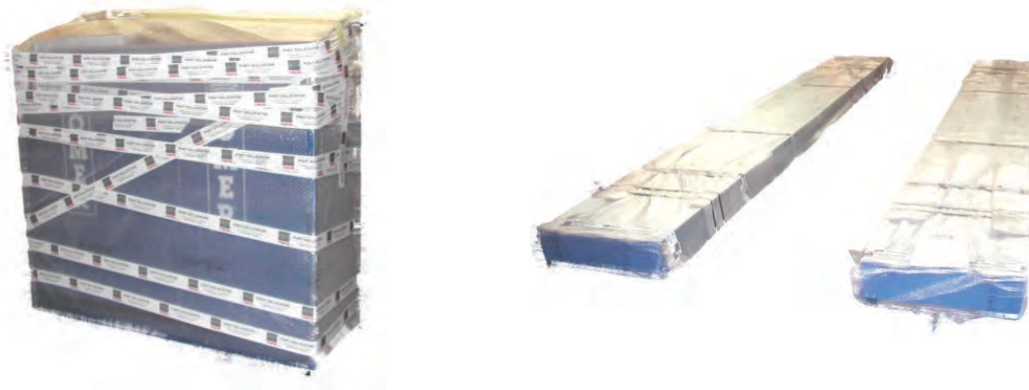

## 4. INSTALLATION

### PACKING LIST

VERSION OF LIFT	WEIGHT		
	Table lbs/kg	Control unit lbs/kg	Ramps lbs/kg
KAR 350 standalone	~ 7000	~ 1200	~ 700
KAR 350 recess-mounted version	~ 7000	~ 1200	/

KAR 350 is usually sent in 4 packages:

- Right platform
- Left platform
- Control unit
- Accessories

The packages may vary according to:

- the size of the lift;
- the type of shipment;
- the packaging used, subject to customer's request;
- the destination country.



DURING TRANSPORT THE CAGE (OR PACKED LIFT) MUST SECURED PROPERLY TO PREVENT IT FROM MOVING AROUND ON THE FLOOR OF THE VEHICLE USED TO TRANSPORT IT.

#### 4.2 Place of installation

To ensure adequate installation please refer to ANSI / ALI ALIS SAFETY requirements for installation and service of automotive lifts

The free space around the lift must satisfy applicable regulations and be no less than 700 mm or 27.5 inches.

**The control unit must be positioned so that the operator has a full view over the lift area**

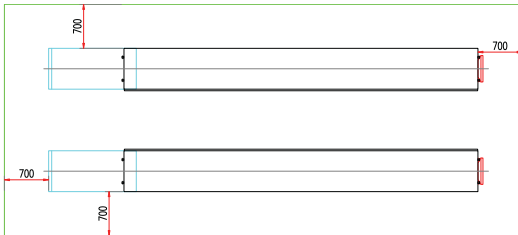

WORK AT A ROOM TEMPERATURE  
 -10° TO 40° C  
 14° TO 104° F.  
**(Indoor use Only)**

To install the anchor bolts, the foundation must have the following characteristics:

FOUNDATION	Tamped
THICKNESS OF CONCRETE	≥ 14 cm (6 in)
CONCRETE RESISTANCE CLASS	≥ C 25
IMPROVED ADHERENCE STEEL GIRDERS	Type Feb 44 K
REINFORCEMENT GIRDERS FOR LARGE SURFACES	Electro welded mesh
REINFORCEMENT GIRDERS FOR SMALL SURFACES	Bent irons
FLATNESS	± 1 / 1000

If the floor characteristics are not available, foundations must be provided underneath the lift's base plates.

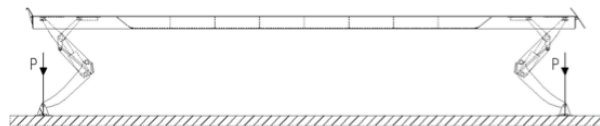

<b>MAX. PRESSURE (*)</b>	Kg / cm <sup>2</sup>	≤ 6
--------------------------	----------------------	-----

## 4. INSTALLATION



### 4.3 **Connecting the lift**

Follow the sequence of operations given below

1. Connect the hoses provided, which lead out of the control unit with their respective inputs to the lift  
(see paragraphs: Hydraulic, pneumatic, electrical connection)
2. Fill the circuit MASTER/SLAVE and remove air from the same circuit.  
(see paragraph: Filling of the circuit Master-Slave)
3. Fix the legs of the lift with the raw plugs at the correct distance and perfectly leveled.  
(see paragraphs: Lift position and Anchorage capsule installation)
4. Carry out all due tests before using the lift.  
(see paragraph: Check and Checks before use)

**The control unit must be positioned so that the operator has a full view over the lift area**

### 4.4. **Connecting the lift's commands**

#### 4.4.1. Hydraulic connections

- Open the control unit door
- Bring the hydraulic hoses from the lift to the control unit, through the hole at the base of the control unit.
- Join the hoses to the hydraulic blocks respecting the numbering system shown (see photo)

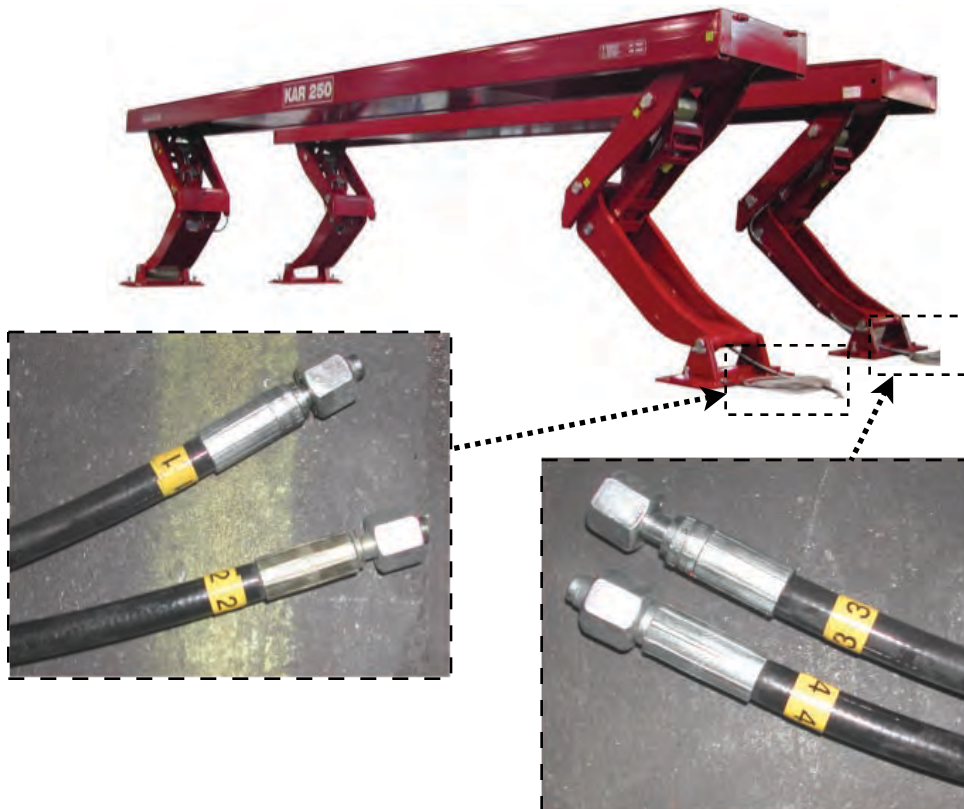

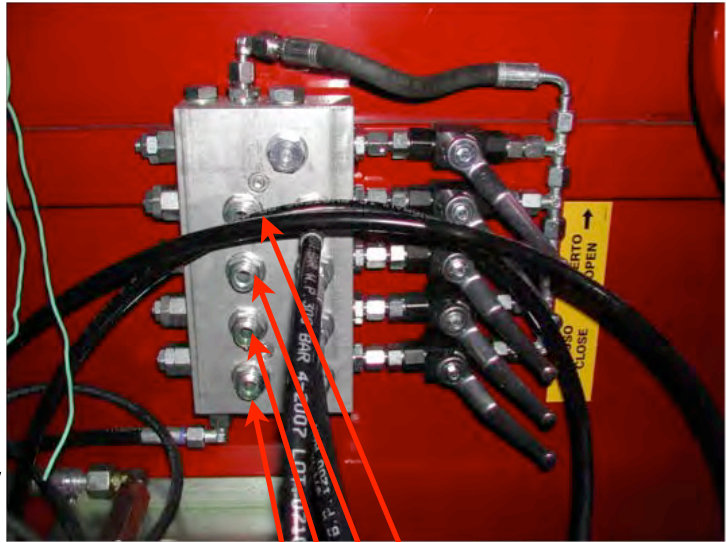

JOIN THE HOSES  
RESPECTING THE  
NUMBERING

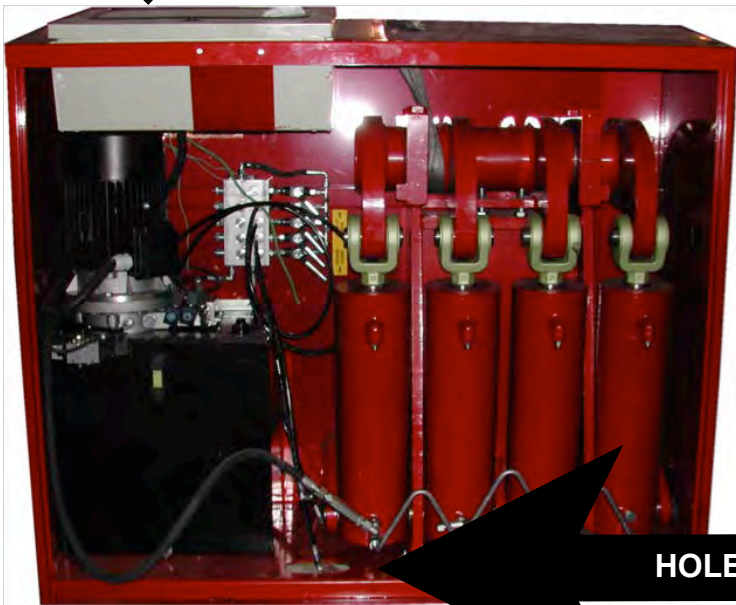

HOLE FOR THE HOSE

## 4. INSTALLATION

#### 4.4.2. *Pneumatic connections*

- Uncoil the pneumatic hose connected to EV2.
- Bring the pneumatic hose from the control unit to the lift, through the hole at the base of the control unit.
- Join the hoses from the platform with the hose from the control unit with a Tee coupling

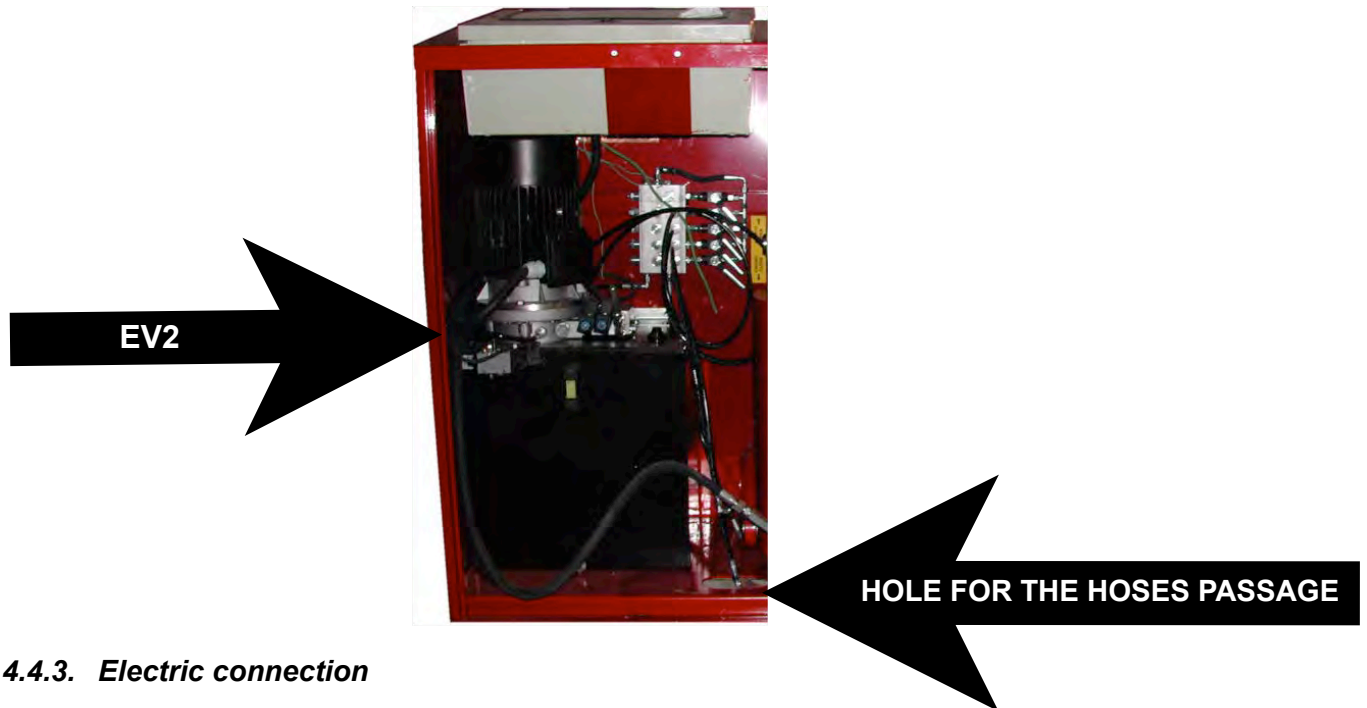

#### 4.4.3. *Electric connection*

The electric supply system must include:

- a main switch with a circuit breaker;
- fuses or thermal protection suited to the machine's characteristics;
- device against accidental contact, for protection

The switch must be positioned in the immediate vicinity of the machine in full compliance with local regulations.

Power cables must have a suitable section for absorbing current, without deviations for other utilities.

Electrical System shall be designed to meet all local / national codes and shall be properly grounded.

The power cable must be locked in the dedicated cable gland and the electric panel must be carefully closed to assure the required IP 54 protection.

Only connect the machine to type approved sockets with grounding cable of proven efficiency.

Periodically have qualified personnel check the correct tightening of the electric cables of the various components.



The electric power cable should be AWG 10 wire.

**Attention:**

- Power the lift's electrical system using a line fitted with a main breaker and without any other junctions.
- The devices fitted to provide protection against short circuits must take into account the features of the electrical equipment:

NOMINAL POWER	HP	10	10
VOLTAGE	V	220 - 240	440 - 480
No. of phases		3	3
FREQUENCY	Hz	60	60
NOMINAL CURRENT	A	28	14
PICKUP CURRENT	A	168	84
PROTECTION	FUSE (DELAYED)	A	35
	FUSE (FAST)	A	50
	THERMOMAGNET	A	50

Warnings for the installation of electric cables between the control unit and lift:  
the connection cable that powers the safety limits switches on the lift must:

- Be adequately protected against the mechanical actions it may be exposed to during use.
- Be passed through the dedicated cable glands (8) and connected to the terminal board (9) inside the electric panel, respecting the numbering of the cable.

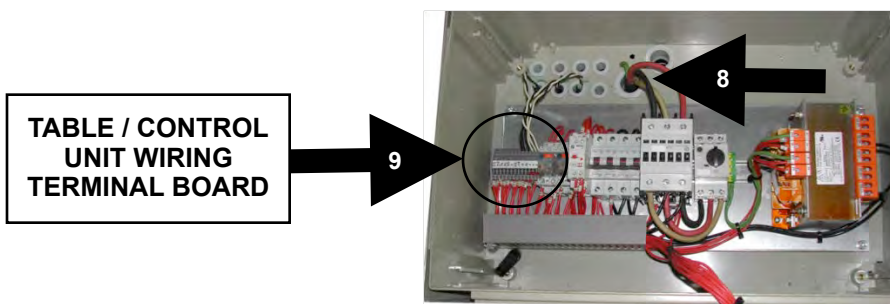

## 4. INSTALLATION

#### 4.5. Filling of the circuit Master-Slave



**PROCEDURE TO BE EXECUTED  
ONLY DURING THE INSTALLATION**

1. Turn the taps on
2. Push button PS / UP till when the lift start lifting
3. Turn the taps off
4. Push button PS / UP till the complete opening of the divider
5. Turn the taps on
6. For each cylinder
  - a. Push button PS / UP till max height of the lift
  - b. Allow air to escape from the air valve till the lift leans on the mechanical safety locks

Repeat point 6 all cylinders

7. Push PS / UP till the max height of the lift
8. Turn the taps off

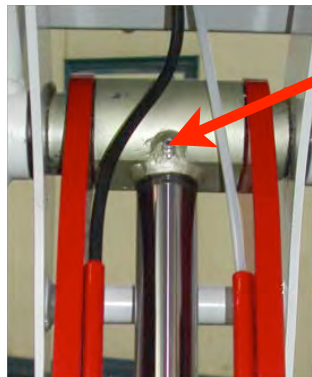
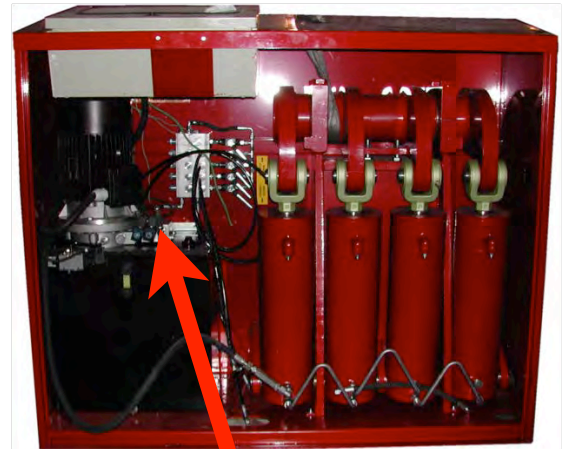
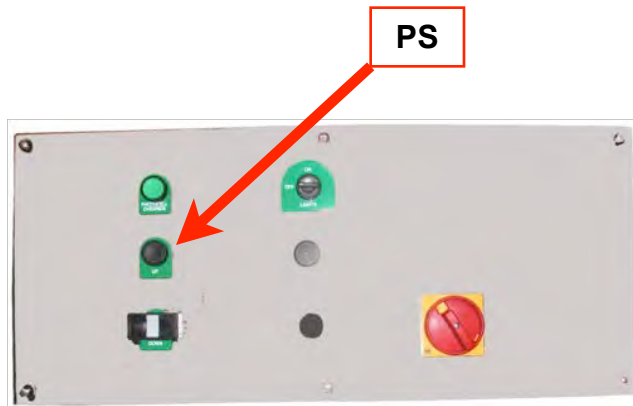

#### 4.6. *Lift position*

1. Place the lift on floor
  - a. aligned
  - b. in parallel
2. Mark on floor the position of the base frames
3. Lifting
4. Put the base frames again in the position alongside the marked line on floor
5. Fix the frames in the position

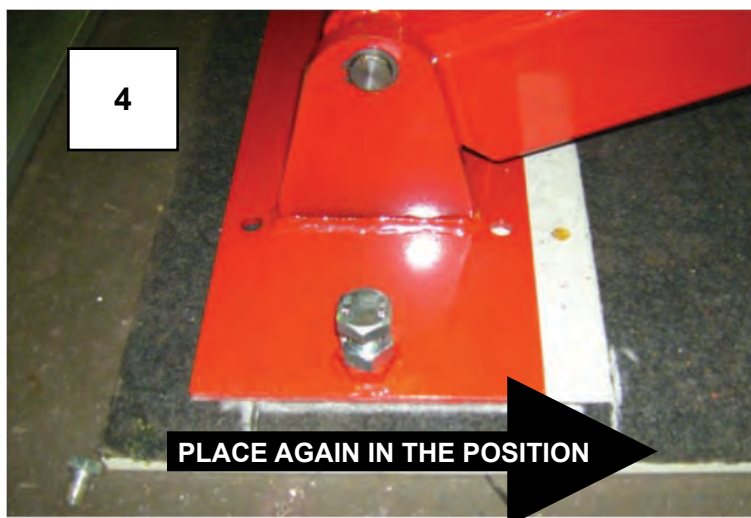
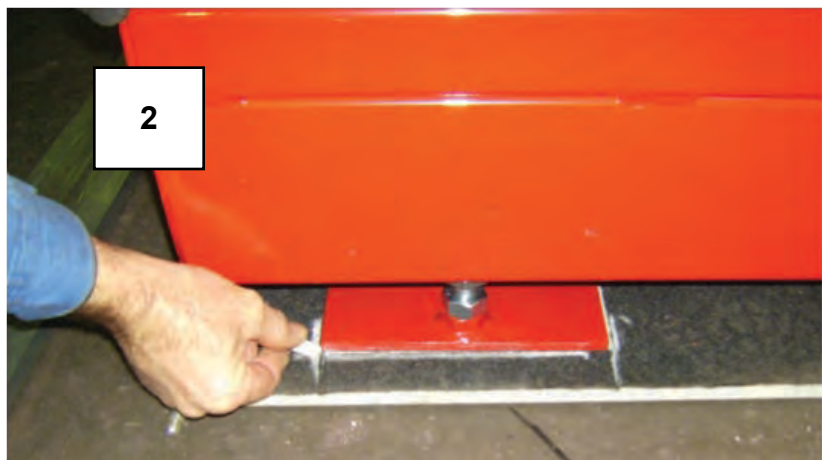

#### 4.7. Check

1. Check that the gap is of  $> X$
2. Screw the nut up to the time that the high of the spring is of  $Y$

X	mm	6
Y	mm	65

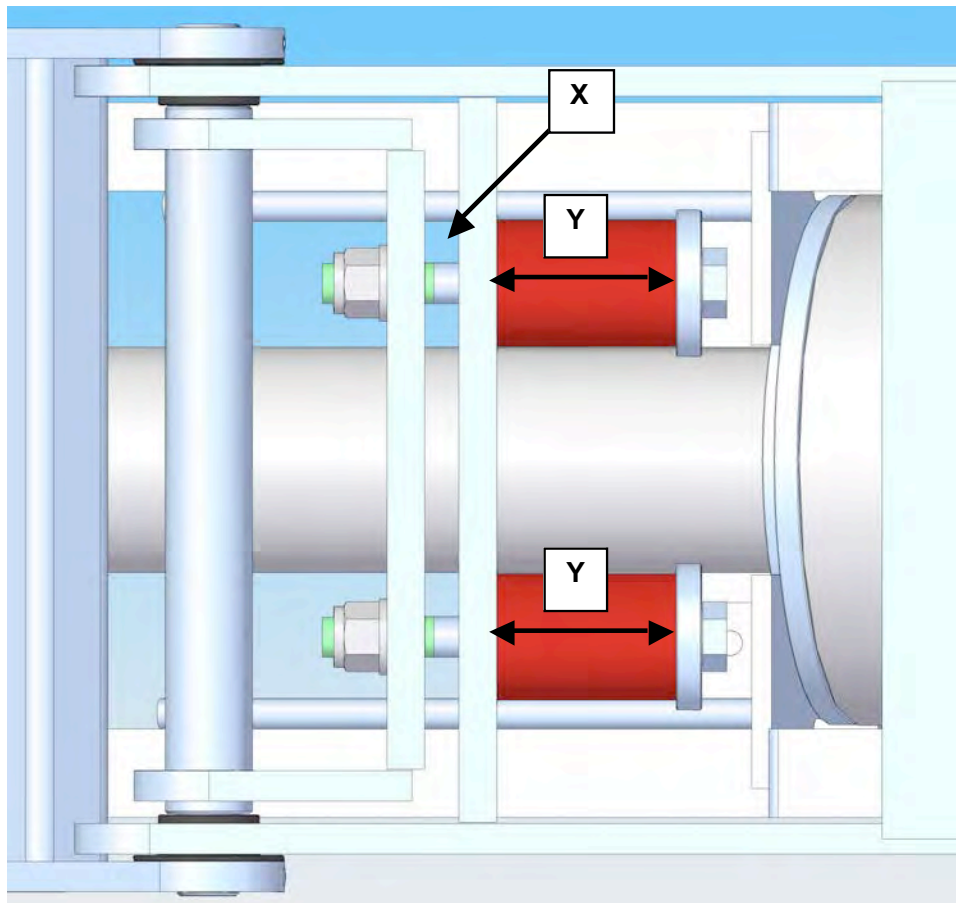

#### 4.8. Anchor Bolt installation

1. Drilling the hole
2. Clean the inside of the hole
3. Push the anchor capsule into the drilled hole
4. Driving the anchor rod into the hole
5. Waiting for the solidification time ( $t_{rel}$ )
6. Waiting for the hardening of the compound ( $t_{cure}$ )
7. Close with the prescribed tightening torque ( $T_{inst}$ )

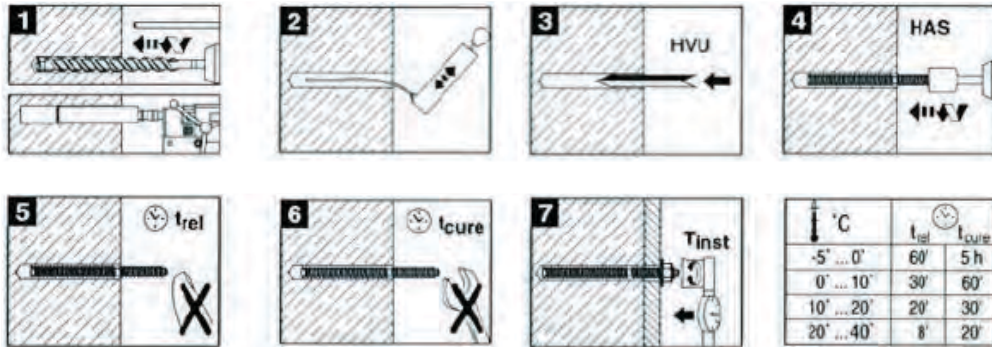

°C	$t_{rel}$	$t_{cure}$
-5° ... 0°	60'	5 h
0° ... 10°	30'	60'
10° ... 20°	20'	30'
20° ... 40°	8'	20'

TYPE OF ANCHOR CAPSULE			HVU M 16X125
TYPE OF ANCHOR ROD			HAS M16X190
DRILL BIT DIAMETER	$d_0$	inch	0.75
MIN. BORE DEPTH	$h_1$	inch	5
MIN. THICKNESS OF CONCRETE	$h$	inch	7
LIFT BASE SPACER		inch	1.5
HOLE DIAMETER		inch	1
TIGHTENING TORQUE	$T_{inst}$	Nm	50 (37 Ft-Lb)
DRILL BIT	TE-T		18/32
NUMBER OF PINS		N°	16 or more

#### ANCHOR BOLT POSITION

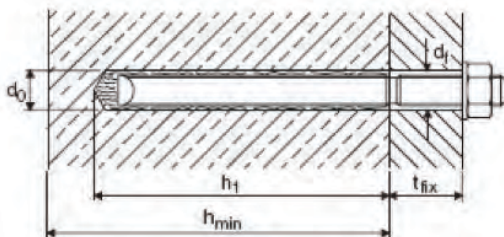

A= OBLIGATORY ANCHOR BOLT  
 B= OPTIONAL ANCHOR BOLT  
 (according to the foundation characteristics and dimension)



## 4. INSTALLATION



#### 4.9 Checks before use

Having completed installation of the lift, the following test must be performed before it can be used for work.

	TEST	STANDARDS
1	Lift leveling	Max. 0.5 mm per meter
2	GAP between the plates and the height of the spring	<i>(see: Check)</i>
3	Sturdiness of anchors fastening to the floor	Tightening torque (50 Nm or 37 Lb-Ft)
4	Pneumatic connections	Diagram <i>(see: Pneumatic diagram paragraph)</i> Air leakage
5	Hydraulic connections	Diagram <i>(see: Hydraulic Diagram paragraph)</i> Oil leakage Pressure
6	Wiring	Diagram <i>(see: Wiring Diagram)</i>
7	Safety devices	<i>(See: Safety device features paragraph)</i>
8	The compressed air system must be powered by filtered and lubricated air	Presence of a filtering system
9	Oil level	Oil level rod
10	Direction of rotation of motor	Arrow on motor
11	Plant cable and piping protection	Cable and pipe covers provided
12	In case of upstroke from opposite side to the torsion bar	Presence of up ramp (optional)
13	Never load vehicles whose overall dimension exceed those of the lift	Loading conditions <i>(see paragraph: Loading conditions)</i>
14	Never load vehicles weighing more than the lift's nominal capacity	Capacity indicated on plate
<b>DATE</b>		<b>SIGNATURE</b>

#### **4.10. FINAL TESTING**

The static and dynamic load test with overloads are performed at the Manufacturer's premises  
The user may perform nominal load test (with  $\pm 10\%$  tolerance admitted for maximum valve calibration) with distribution of the loads as described in the Loading conditions paragraph of the installations, use and maintenance manual.

Test can be carried out with the following "overloading factors"

STATIC TEST	overload	150%
DYNAMIC TEST	overload	115%

With loading distributed according the foreseen scheme of the machine of the machine in the chapter "*Loading conditions*"

5.  USE

Attention to:

- USER
- OPERATOR / SPECIALIZED TECHNICIAN

**5.1 Operation commands**

<b>I</b>	<b>SYSTEM MAIN SWITCH</b>
	Activating this switch, the control panel is enable
<b>PS</b>	<b>TABLE UP BUTTON</b>
	Activating this switch, the vehicle lift begins lifting
<b>PDA</b>	<b>LT DOWN BUTTON</b>
<b>PDB</b>	<p>1 By pressing the button <b>PDLTA</b>, the auxiliary lift <b>LT</b></p> <p>a) Start the lowering</p> <p>b) Stops when the <b>LT</b> platform is about 120 mm from floor</p> <p>2 The lamp <b>SLPDLT</b> turns on</p> <p>Press together the buttons <b>PDLTA &amp; PDLTB</b>, in order to end the last lowering phase; the buzzer sound (<b>BZ</b>)</p>
<b>PEFT</b>	<p><b>CUT-OFF KEY SWITCH PHOTOCELLS</b></p> <p>The tables are provided with photocells to check platform synchronization. If there is a difference in height of more than 50 mm, the photocells interrupt the electric circuit that powers the control unit (24 volts).</p> <p>Use the <b>PEFT</b> key to exclude the photocells; in this case, by keeping the <b>PEFT</b> button turned it is also possible to perform the upstroke (<b>PS</b>) and downstroke operations (<b>PD</b>)</p>
<b>BZ</b>	<b>BUZZER</b>
<b>PL</b>	<b>LIGHT SWITCH</b>

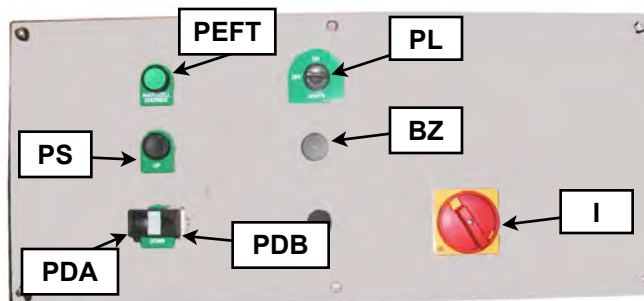

PROCEDURE	WHEN	PURPOSE	SEE YOU	
			CHAPTER	PARAGRAPH
Platforms levelling	once a week	To replace the normal outflow of the hydraulic components	Maintenance	Platforms levelling
Manual checks of the photocells	Once a day	To check the correct functioning of the photocells	Maintenance	Photocells

## 6. MAINTENANCE



The lift controls and safety devices should be checked periodically by the user to assure ongoing efficiency.  
**All routine maintenance operation should be performed by trained staff operating in full safety**

### Attention to:

-OPERATOR / SPECIALIZED TECHNICIAN

#### 6.1. Ordinary / extraordinary maintenance

We recommend the following ordinary and extraordinary routine maintenance operations

		WHERE	WHAT	MACHINE STATUS	HOW	TYPE OF GREASE	TYPE OF LUBRICANT
ORDINARY	80 h	UNDER BASE PLATFORM	SLIDERS (PAD)	OFF	GREASE	MOLYCOTE G-4700	
	80 h	PNEUMATIC CIRCUIT	CYLINDER - TUBE CONNECTIONS	IN MOTION	VISUAL INSPECTION		
	80 h	STRUCTURE	PINS AND SUPPORTS	OFF	LUBRICATE GREASE	MOLYCOTE G-4700	
	80 h	HYDRAULIC CIRCUIT	CYLINDER - TUBE CONNECTIONS	IN MOTION	VISUAL INSPECTION		
	3 months	STRUCTURE	PHOTOCELLS	IN MOTION	CHECK OF THE CORRECT WORKING		
EXTRAORDINARY	12 months	HYDRAULIC UNIT	TANK + FILTER	OFF	CHECK CLEAN		
	24 months	HYDRAULIC UNIT	TANK	OFF	OIL CHANGE (If required by the oil dirt)		HYDROIL GF 46
	12 months	STRUCTURE	BUSHES	OFF	CHECK OF THE WEAR		
	12 months	ELECTRIC CIRCUIT	ELECTRIC SECURITIES	IN MOTION	CHECK OF THE CORRECT WORKING		
	12 months	STRUCTURE	SAFETY LOCKS	OFF	INTEGRITY CHECK		

**Note: Before starting any maintenance on the lift, please ensure the lift system has been “lockout / tagout” as per ANSI Z244.1**

**LUBRICATING POINTS (repeat on all 4 legs)**



## 6.2 Table adjustment procedures

### 6.2.1. Maximum pressure valve calibration



The calibration of the valve must be done by an authorized service technician from the manufacturer.  
After the calibration the valve must be sealed for example with sealing wax.

- 1) Take the table to maximum height
- 2) Connect a pressure gauge to the output (part A)
- 3) Loosen the nut by turning two revolutions anticlockwise (part B)
- 4) Keeping the up command button pressed, check the pressure on the pressure gauge
- 5) Adjust pressure with a screwdriver (part C)
- 6) When the pressure is equal to P, fix the loosened nut at point

PRESSURE	P	psi	3626
----------	---	-----	------

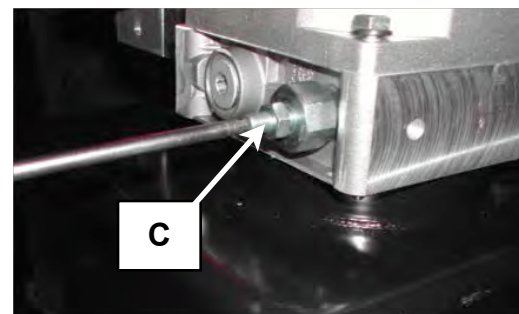
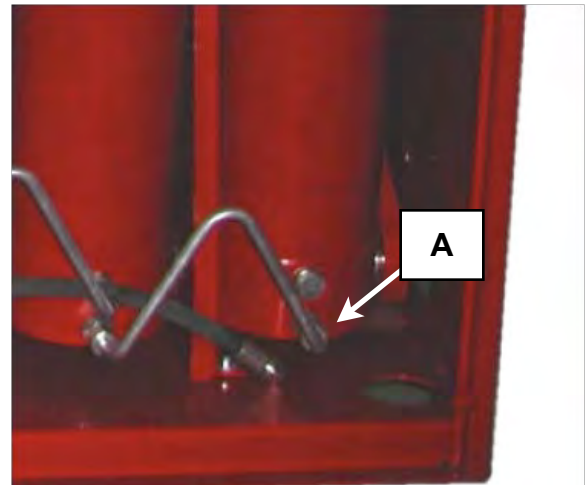
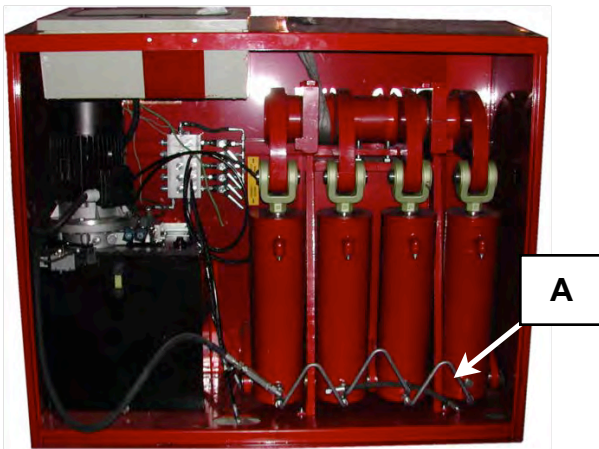

## 6.2.2. Photocell

### 6.2.2.1. Alignment



The alignment procedure of the photocells has to be carried out by specialized people and authorized from the manufacturer.

<b>NORMAL STATUS</b>	• RED LED ON
<b>STOP STATUS</b>	• RED LED OFF
<b>POSITIONING CHECK</b>	• With a sheet parallel to the reflector move downwards • check when the RED LED is switched off • mark the position
	• with a sheet parallel to the reflector move upwards • check when the RED LED is switched off
	a) mark the position
	b) the work field is between the two marks
	c) the lift's permitted operating field must be $\pm 50$ mm

### 6.2.2.2. Functioning test

Interrupt "photocell beam" using a matt object and check":

A	With vehicle lift stopped	The lift can be not activated from the control panel
B	With vehicle lift on the go	The lift movement has to stop

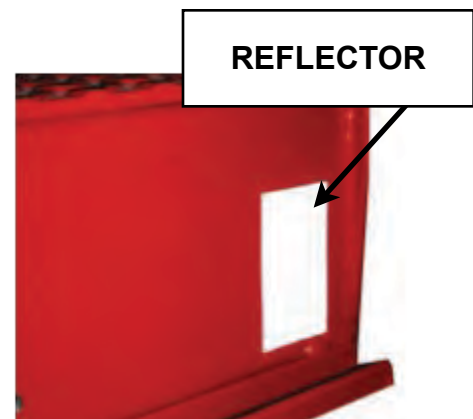

### 6.2.3 Velocity Fuse



The calibration of the valve must be drive by an authorized service technician from the manufacturer.  
THE CALIBRATION DISTANCES MUST BE ESTABLISHED BY THE MANUFACTURER.

1. Remove the valve (1) on the bottom of the piston using the key provided (2)
2. Loosen the washer and lock nut (3) beneath the valve
3. Move the plate of the valve (4) closer or further away as desired, checking the height with the dedicated thickness gauge (5)

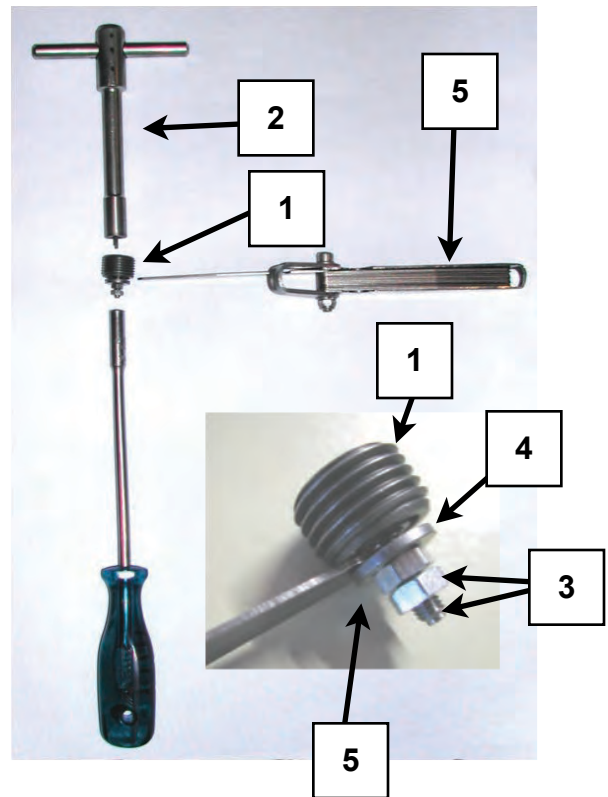
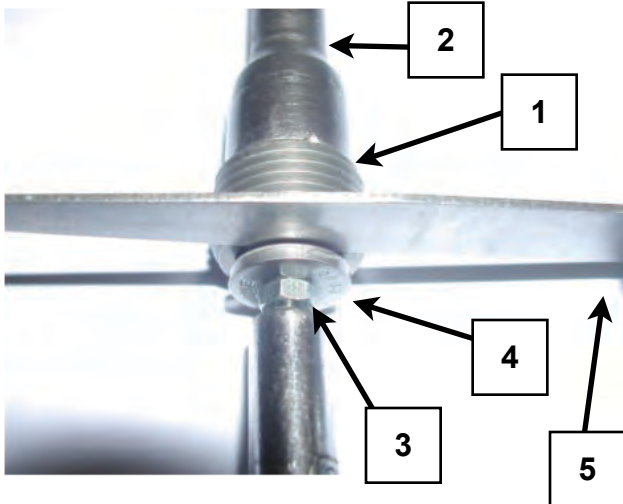



### 6.2.4 Platform levelling



THE PROCEDURE OF PLATFORM LEVELLING MUST BE EXECUTED STRICTLY **WITHOUT THE CAR ON THE LIFT**

**YES**



**NO**

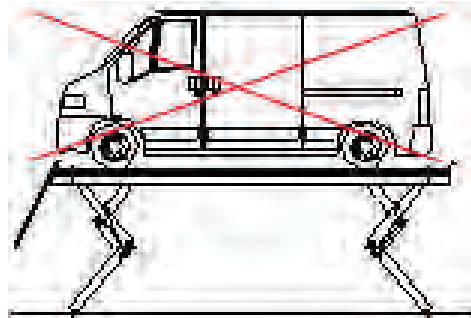

1. Lift using the button of "upward" PS until max weight is reached
2. Turn the taps on
3. Push PS/UP
4. Turn the taps off

**PS**

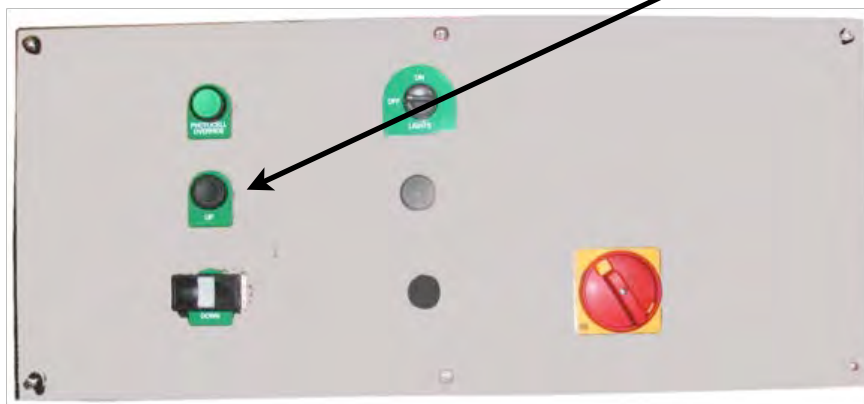

### 6.2.5 Unblocking safety locks



The “unblocking procedure” has to be carried out from authorized service technician from the manufacturer.

Procedure to be done , when a “safety lock” is on blocking position:

1. Open the feed valve of the slave circuit of the involved cylinder
2. Activate the hand pump till when the “safety locked” is blocked
3. Close the “feed valve” of the slave circuit
4. Lower the lift
5. Discharge the loading
6. Fill the slave circuits

### 6.2.6 Eliminating air from the volumetric circuit

To eliminate the air from the circuit, proceed as follows:

1. Take the lift to its maximum height
2. Connect breather pipe of the first slave cylinders to a tank using a flexible PULLY hose
3. Open the breather pipe a little send oil to the volumetric circuit using the dedicated switch
4. Repeat the procedure for the other 3 cylinders
5. Close the breather pipe
6. Lower by about 18”
7. Repeat this procedure al least 3 times until all the air has been eliminated from the circuit

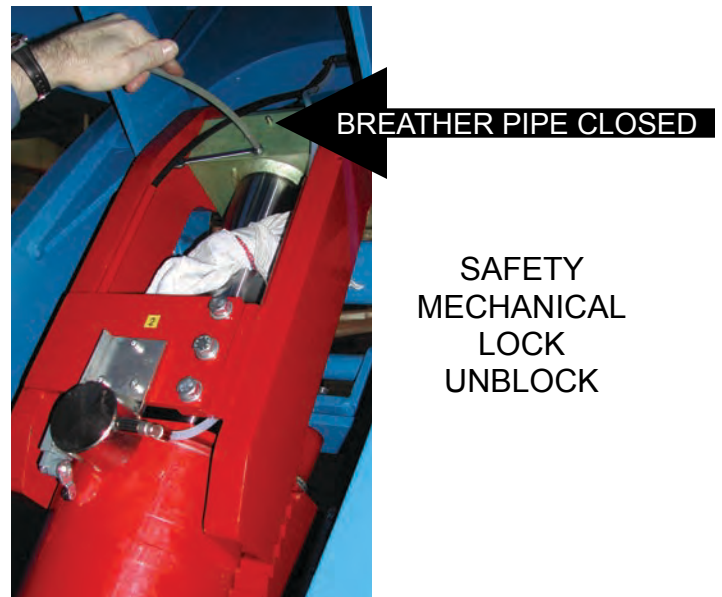
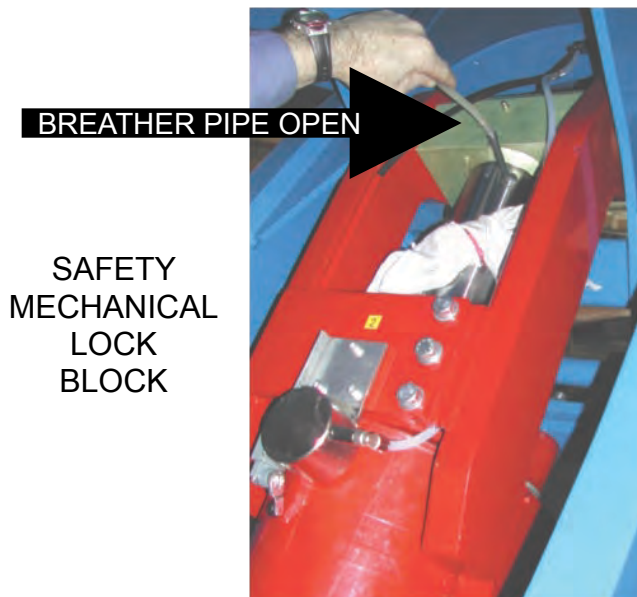

### 6.3. Safety lowering

#### MANUAL LOWERING WITH HAND PUMP (accessory available on request)

**Operations to be performed to lower raised platform with vehicle on the case of a power outage:**

- Insert the lever on the dedicated pump support
- Unscrew the lock nut valve EV3, fully unscrew the knurled pin (see photograph) and allow the table to lower
- Pump until the safety jacks move away from the block position
- Activate jack opening using the dedicated manual valve on solenoid valve EV2 (turn screw A through 90°)

**ENSURE THAT THE ALL 4 MECHANICAL SAFETY DEVICES ARE OPEN**

- Unscrew the lock nut on valve EV1, fully unscrew the knurled pin (see photograph) and allow the table to lower
- To restore, return the manual command of valve EV2 to its position and tighten the knurled pins

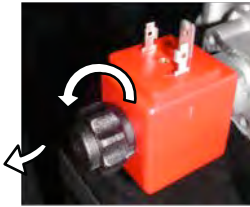

A

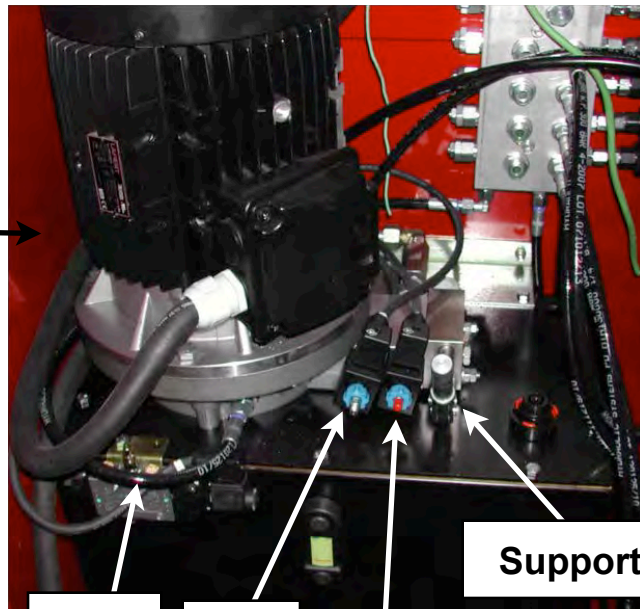

EV2

EV1

EV3

Support-PUMP

#### 6.4. Abnormal operation

WHAT HAPPENS	WHERE	CHECK
The lift does not rise and the motor does not start	<ul style="list-style-type: none"> <li>• FUSES</li> <li>• THERMAL RELAY</li> <li>• TRANSFORMER</li> <li>• MOTOR</li> <li>• CONTACTOR</li> <li>• PHOTOCELLS</li> </ul>	a.1. line fuse blown a.2. 24 volt fuse blown b.1. thermal relay tripped, re-set c.1. transformer burnt out, does not emit 24 volt d.1. motor short-circuited or burnt out e.1. contactor C1 burnt out f.1. photocell fault f.2. photocells out of reading range
The lift does not rise and the motor starts	<ul style="list-style-type: none"> <li>• HYDRAULIC PUMP</li> <li>• DISCHARGE VALVE</li> <li>• LIMIT VALVE</li> <li>• MOTOR</li> </ul>	a.1. o-ring seal broken a.2. key broken a.3. aspiration tube broken a.4. clamping screws loose a.5. check oil leakage a.6. check the pressure value b.1. EV1 remains open c.1. limit valve broken d.1. Check that the motor turns in the direction shown by the arrow
The lift does not lower and the pressure is normal	<ul style="list-style-type: none"> <li>• PHOTOCELLS</li> <li>• TRANSFORMER</li> <li>• HYDRAULIC VALVE</li> <li>• MECHANICAL SAFETY DEVICES</li> <li>• AIR VALVE</li> </ul>	a.1. photocells fault a.2. photocells out of reading range b.1. transformer burnt out, does not emit 24 volt c.1. EV1 blocked c.2. check the velocity fuse on the bottom of the dual effect cylinders d.1. EV1 24 V coil burnt out e.1. mechanical safety devices mechanical blocked f.1. EV2 air blocked (does not open the mechanical safety devices) f.2. EV2 requires power
The lift rise not leveled	<ul style="list-style-type: none"> <li>• CYLINDERS</li> <li>• VALVE</li> </ul>	a.1. air in the circuit a.2. seal wear : SLAVE and/or MASTER b.1. oil leak from the filling valves
Metallic noise	<ul style="list-style-type: none"> <li>• BUSHING</li> </ul>	a.1. bushing wear
Raising intermittently	<ul style="list-style-type: none"> <li>• PINS</li> </ul>	a.1. pin damage

**7. Accessories**

<b>CODE</b>	<b>DESCRIPTION</b>	<b>PHOTOGRAPH</b>
4033041400	LIGHTING SYSTEM (NEON STRIPS) (only for standalone)	 A photograph of a long, thin, white neon strip lighting system with black end caps.