

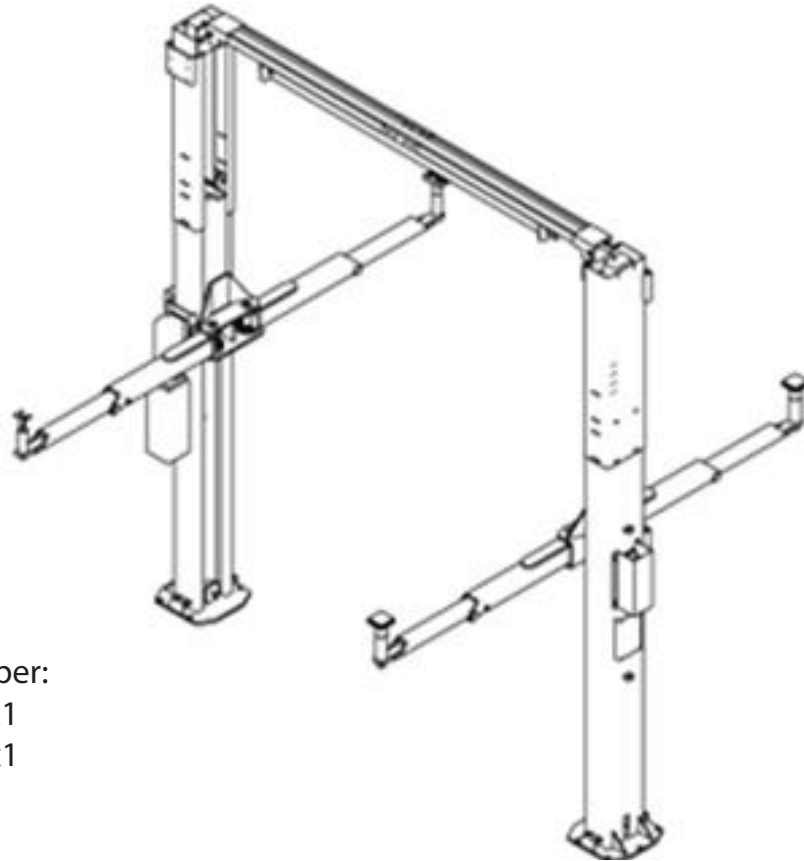

TOTAL AUTOMOTIVE LIFTING SOLUTIONS INC.



Model Number:  
TLS210SRx1  
TLS210SXx1

10,000 lb (4536 kg) Symmetric Two Post

# Installation / Operation & Service Parts Manual

READ the Manual Thoroughly Before Installing,  
Operating, Servicing, or Maintaining the Lift

SAVE this MANUAL and ALL INSTRUCTIONS

Total Automotive Lifting Solutions Inc.  
2300 Speers Rd. Oakville, Ontario L6L 2X8  
Phone: (905) 847-1198 Fax: (905) 891-1214  
www.TLSLifts.com

Part Number : D -TP -10 -S  
Issue 00 5 Effective : May 1, 200 9  
Supersedes Issue 00 4 - April 15, 200 9

Your new lift will provide years of dependable service if installed, operated and maintained properly. **Read and be prepared to follow all safety, installation, operation, and maintenance instructions in this manual before installing and operating the lift. In addition, read and follow all safety and other information included on and with the lift before operating the lift. Keep this manual in a secure place for future reference, training and service part identification.**

## **TABLE of CONTENTS**

1. Unloading Procedure and Lift Package Contents	page 3
2. Warranty and Safety	page 4 - 6
3. General Requirements and Lift Specifications	page 7
4. Tools Required and Pre Installation Procedures	page 8
5. Installation Procedures	page 9 - 10
6. Operating Instructions and Lift Maintenance	page 11 - 13
7. Troubleshooting	page 14
8. Lift Installation Diagrams and Parts Lists	page 15 - 26

**IMPORTANT** : It is the shop owner's responsibility to provide a satisfactory installation area for the lift. Lifts should only be installed indoors on level concrete floors with a minimum of 4 inches (102mm) and 3000 psi (20.7MPa) concrete that has been aged a minimum of 30 days. Please consult a qualified individual if any doubt exists concerning proper installation and subsequent safe operation of the lift. Do not install the lift on asphalt or outdoors.

Prior to installation, it is the shop owner's responsibility to provide constant electrical power in the correct voltage, phase, etc., and all wiring for electrical hook-up of the lift. The shop owner must insure that the electrical installation conforms to local building and safety codes. Where required, the shop owner will provide an electrical isolation switch located in close proximity to the lift. This switch will have an emergency stop capability and isolate electrical power from the lift for servicing requirements.

Hydraulic oil cannot be shipped with the lift and will be supplied by either the shop owner or the installer. ISO 32 hydraulic oil (10W non detergent hydraulic oil) must be used to fill the reservoir tank before operating the lift.

**It is the shop owner's responsibility to train all operators in lift operation and safety.**

## **UNLOADING PROCEDURE and LIFT PACKAGE CONTENTS**

### **For your information:**

All lift components are grouped together in one package held at each end by steel frames.

### **Unpacking Procedure:**

- When the lift arrives on site:
- If possible have lift unloaded in the installation area.
  - Check for freight damage and report immediately to the trucking company who delivered the lift.
  - Check for missing parts and report immediately to the factory.  
1 - 877 - 799 - LIFT (5438) or (905) 847 - 1198

### **Main Components include:**

Power Side Column and Carriage Assembly – 1 pc (c/w equalizing cable and 2 arm restraint assemblies)  
Opposite Side Column and Carriage Assembly – 1 pc (c/w equalizing cable and 2 arm restraint assemblies)  
Column Extensions – 2 pc  
Overhead Crossmember – 3 pc (c/w 4 steel cable pulleys)  
Overhead Safety Shutoff Bar – 1 pc  
Arms – 4 pc (c/w arm restraint gear assemblies)  
Powerpack Assembly – 1 pc

### **Accessory and Hardware Box includes:**

Micro-switch for Overhead Safety Shutoff Bar - 1pc (c/w 2 mounting brackets and hardware)  
Baseplate Shims (6mm - 3mm - 1mm assortment) - Anchor Bolt Assemblies - 10 pc  
Arm Pins – 4 pc (c/w roll pins to secure them)  
Rubber Stack Pad Assembly – 4 pc  
Stack Pad Adapter (1½" ) – 4 pc  
Stack Pad Adapter (3") – 4 pc  
Stack Pad Adapter (6") – 4 pc  
Honda Adapter – 2 pc  
Rubber Door Guards – 2 pc  
Hydraulic Hose – 2 long and 1 short (also 1 hydraulic "T" fitting and powerpack adapter fitting)  
Rubber Mounts for Powerpack - 4 pc  
Safety Lock Release Cable – 1 pc (c/w 2 pulley brackets and fittings)  
Safety Lock Cover – 2 pc  
Fittings Box (bolts, washers, nuts, screws, cable ties, etc.)  
ALI - WL101 Series Label Kit  
ALI - " Lifting It Right " Manual  
ALI - " Vehicle Manufacturer's Lifting Point Guide" (CD)  
Automotive Lift Safety Tips Hang Card  
Automotive Lift, Operation, Inspection and Maintenance Manual  
Owner's Manual

## **WARRANTY and SAFETY**

**Warranty:** The multi-metric model two post lifts listed in this manual have the following warranty from date of purchase:

**Structural Components - 1 year**  
**Hydraulic and Other Components - 1 year**

**Accessory Items - 90 days**  
**Labor - 1 year**

The above items are warranted to be free of defects in material and workmanship to the original owner of the lift as follows: During the first year (90 days for accessories), those parts proven after inspection to be defective shall be repaired or replaced at the option of the manufacturer. This warranty does not extend to defects caused by ordinary wear, misuse, abuse, improper maintenance, shipping damage or where repairs have been attempted or made by anyone other than the manufacturer or a manufacturer certified technician. This warranty is exclusive and in lieu of all other warranties express or implied. In no event shall the manufacturer be liable for special, incidental or consequential damages for any breach or delay in performance of the warranty. The manufacturer reserves the right to change specifications, designs or add improvements to its product line without incurring any obligation to make such changes to products sold previously.

## **IMPORTANT SAFETY INSTRUCTIONS**

When using your garage equipment, basic safety precautions should always be followed, including the following:

1. Read all instructions
2. Care must be taken as burns can result from touching hot parts
3. Do not operate equipment with a damaged cord or if equipment has been dropped or damaged – until it has been examined by a qualified service person
4. Do not let a cord hang over the edge of the table, bench, or counter or come in contact with hot manifolds or moving fan blades
5. Let equipment cool completely before putting away. Loop cord loosely around equipment when storing
6. To reduce risk of fire, do not operate equipment in the vicinity of open containers of flammable liquids (gasoline)
7. Adequate ventilation should be provided when working on operating internal combustion engines
8. Keep hair, loose clothing, fingers, and all parts of body away from moving parts
9. To reduce the risk of electric shock, do not use on wet surfaces or expose to rain
10. Use only as directed in this manual. Use only manufacturer's recommended attachments
11. ALWAYS WEAR SAFETY GLASSES. Everyday eyeglasses only have impact resistant lenses, they are not safety glasses

## **SAVE THESE INSTRUCTIONS**

**safety cont'd on page 5**

## **Safety Continued**

Basic common sense safety precautions should always be followed when installing, operating and maintaining the lift as a risk of fire, electric shock, or injury may be present.

### **In addition:**

1. Read and follow all safety instructions and decals included with the lift. Read and follow all safety instructions in this manual. Read and follow the ALI "Lifting It Right" manual - included with the lift. **Always** use the "Vehicle Lifting Points" reference guide when lifting a vehicle – CD is included with the lift. Insure all materials stay up to date >>> [www.autolift.org/](http://www.autolift.org/)
2. Only trained and authorized personnel should position a vehicle and operate the lift. Do not allow customers or bystanders to operate the lift or be in the lift area.
3. Inspect the lift daily. Do not operate if potential problems have been identified or lift malfunctions. Do not operate if lift has damaged or broken components. Never walk or work under the lift unless all safety locks are completely engaged.
4. Never overload the lift. The rated capacity decal is located on the powerpack column. The hydraulic system on this lift is not designed to be a load holding device. Mechanical safety locks must be engaged before proceeding under the lift, with vehicle servicing, or system maintenance. Never override operating controls. This is unsafe and will void the warranty.
5. Before driving a vehicle between the columns, position all arms to insure unobstructed entry. Do not hit or run over arms as this could damage the lift and/or vehicle.
6. Use all 4 arms to raise a vehicle. Position all lift pads to contact vehicle manufacturer's recommended lifting points (see "Vehicle Lifting Points" reference guide CD included with the lift). Raise lift slowly until all pads contact the vehicle. Check all pads for complete and secure contact with the vehicle. Check all arm restraints to insure they are engaged properly. Check that vehicle is stable on the lift. Only after confirming these procedures, raise the lift to desired working height.
7. Special care must be used when lifting pick-up trucks. Optional truck adapters may be required to reach manufacturer recommended lifting points. Always use these lifting points. Running boards and other installed accessories may also require optional adapters Insure contents of the cargo box will not affect vehicle balance while on the lift.
8. **Important:** Removal or installation of heavier parts can change the vehicle's center of gravity on the lift resulting in a critical load shift. The vehicle may then be unstable. Plan ahead for this possibility to insure continued safety and refer to the vehicle manufacturer's service manual for recommended procedures.
9. Always keep the lift area free of obstructions and debris. Clean up grease and oil spills immediately.
10. Never raise a vehicle with passengers inside. Before lowering a vehicle, check the lift and lift area and remove all obstructions. Before removing vehicle from the lift or lift area, position arms to the drive through position and confirm an unobstructed exit.

**safety cont'd on page 6**

# Safety Instruction and Information Decal Kit (included with the lift)

 <b>CAUTION</b> Lift to be used by trained operator only.	 <b>CAUTION</b> Authorized personnel only in lift area.	 <b>WARNING</b> Clear area if vehicle is in danger of falling.	 <b>WARNING</b> Position vehicle with center of gravity midway between adapters.
 <b>CAUTION</b> Use vehicle manufacturer's lift points.	 <b>CAUTION</b> Always use safety stands when removing or installing heavy components.	 <b>WARNING</b> Remain clear of lift when raising or lowering vehicle.	 <b>WARNING</b> Avoid excessive rocking of vehicle while on lift.
 <b>CAUTION</b> Use height extenders when necessary to ensure good contact.	 <b>CAUTION</b> Auxiliary adapters may reduce load capacity.	 <b>WARNING</b> Do not override self-closing lift controls.	 <b>WARNING</b> Keep feet clear of lift while lowering.

The messages and pictographs shown are generic in nature and are meant to generally represent hazards common to all automotive lifts regardless of specific style.  
Funding for the development and validation of these labels was provided by the Automotive Lift Institute, PO Box 85 Cortland, NY 13045.  
Replacement label sets may be obtained from the original lift manufacturer and ALI's member companies. They are protected by copyright.  
www.autolift.org ©1992 by ALL, Inc. ALIWL101s

 <b>SAFETY INSTRUCTIONS</b> Read operating and safety manuals before using lift.	 <b>SAFETY INSTRUCTIONS</b> Proper maintenance and inspection is necessary for safe operation.
 <b>SAFETY INSTRUCTIONS</b> Do not operate a damaged lift.	<p>The messages and pictographs shown are generic in nature and are meant to generally represent hazards common to all automotive lifts regardless of specific style. Funding for the development and validation of these labels was provided by the Automotive Lift Institute, PO Box 85 Cortland, NY 13045. Replacement label sets may be obtained from the original lift manufacturer and ALI's member companies. They are protected by copyright. www.autolift.org ©1992 by ALL, Inc. ALIWL101s</p>

**Review all safety information daily with all lift operators**

**IMPORTANT : Insure Safety Instruction decals are affixed to the lift immediately following installation and before the lift is used**

## ELECTRICAL SAFETY DECAL

<p><b>ATTENTION :</b> MOTEUR NON PROTÉGÉ -- PROTECTION EXTÉRIEURE CONTRE LA SURCHAUFFE DOIT ÊTRE ASSURÉE CONFORMÉMENT AU CODE CE, PREMIÈRE PARTIE</p> <p>COURANT ADMISSIBLE MINIMAL DE LA DÉRIVATION : 20 A.</p> <p>COURANT NOMINAL MAXIMAL DU FUSIBLE DE LA DÉRIVATION : 25 A.</p> <p><b>AVERTISSEMENT :</b> IL EST DANGEREUX DE TROP ARROSER LE MATÉRIEL ET LES CÂBLES ÉLECTRIQUES</p> <p>SI CONNECTÉ À UN CIRCUIT PROTÉGÉ PAR DES FUSIBLES UTILISER DES FUSIBLES À UNE ACTION DIFFÉRÉE MARQUÉS "D"</p> <p>NE PAS UTILISER À UN NIVEAU INFÉRIEUR À CELUI DU PLANCHER DU GARAGE OU DU SOL</p> <p><b>CAUTION :</b> RISK OF ELECTRIC SHOCK – DO NOT REMOVE COVER – NO USER SERVICEABLE PARTS INSIDE – REFER SERVICING TO QUALIFIED SERVICE PERSONNEL</p> <p><b>SAFETY INSTRUCTIONS</b> IF ATTACHMENTS, ACCESSORIES OR CONFIGURATION MODIFYING COMPONENTS THAT ARE LOCATED IN THE LOAD PATH, AFFECT OPERATION OF THE LIFT, AFFECT THE LIFT ELECTRICAL LISTING OR AFFECT INTENDED VEHICLE ACCOMMODATION ARE USED ON THIS LIFT AND, IF THEY ARE NOT CERTIFIED FOR USE ON THIS LIFT, THEN THE CERTIFICATION OF THIS LIFT SHALL BECOME NULL AND VOID. CONTACT THE PARTICIPANT FOR INFORMATION PERTAINING TO CERTIFIED ATTACHMENTS, ACCESSORIES OR CONFIGURATION MODIFYING COMPONENTS.</p>	<p><b>CAUTION :</b> MOTOR NOT PROTECTED -- EXTERNAL OVERHEAT PROTECTION IN ACCORDANCE WITH CE CODE, PART I, MUST BE PROVIDED</p> <p>MINIMUM CIRCUIT AMPACITY OF CONDUCTOR IS 20 A.</p> <p>MAXIMUM BRANCH CIRCUIT FUSE IS 25 A.</p> <p><b>WARNING :</b> IT IS DANGEROUS TO OVERSPRAY THE ELECTRICAL APPARATUS AND WIRING</p> <p>IF CONNECTED TO A CIRCUIT PROTECTED BY FUSES USE TIME DELAY FUSE MARKDE "D"</p> <p>DO NOT USE BELOW GARAGE FLOOR OR GRADE LEVEL</p>
---	--

**LIFT SAFETY and LIFT MAINTENANCE MUST BE PART OF YOUR DAILY ROUTINE**

**SYMMETRIC GENERAL REQUIREMENTS and LIFT SPECIFICATIONS**

**10,000 lb. Capacity** (2,500 lbs. per lift pad)

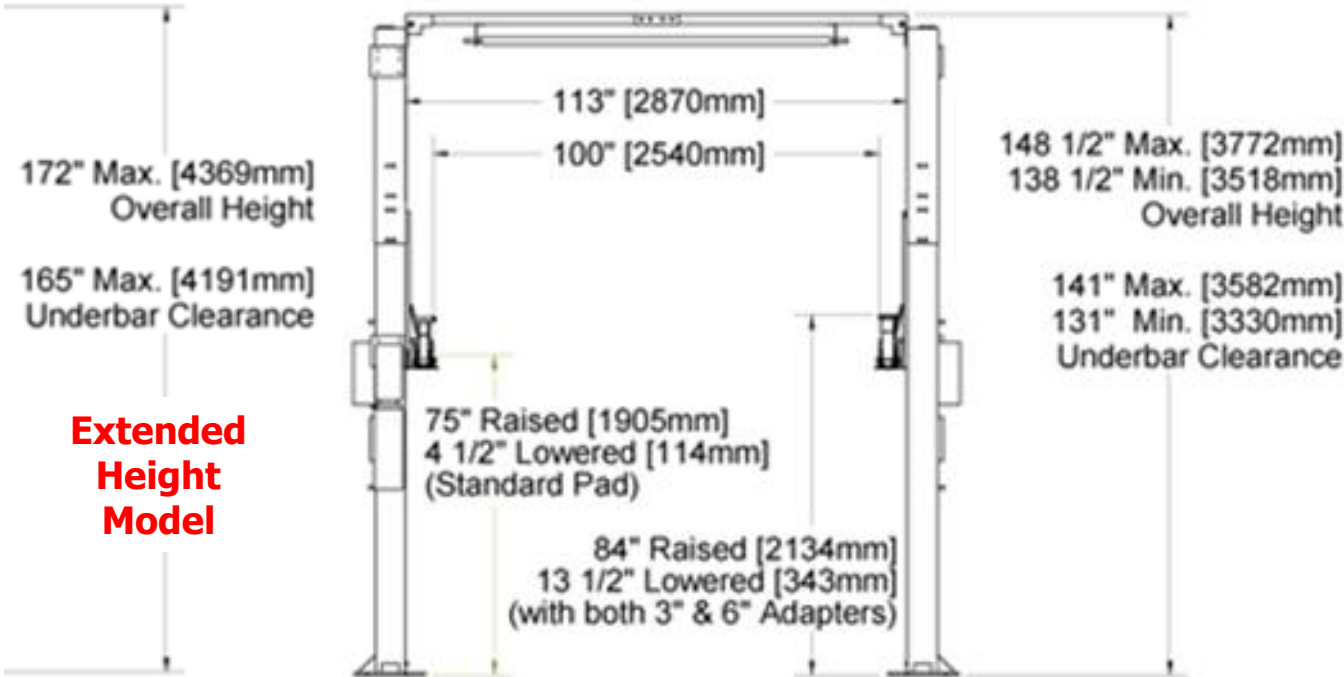
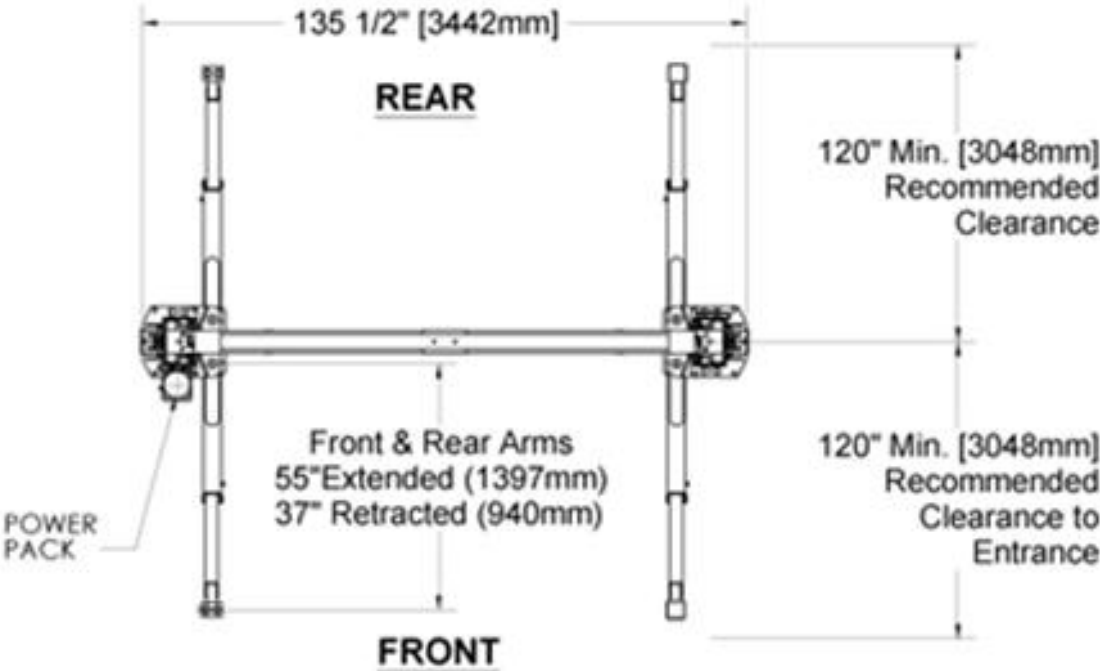

**Concrete:**

**minimum 4 inches (102mm) - 3000 psi (20.7MPa) - aged a minimum of 30 days.**

**Electrical:**

**230V - 1 ph - 60 Hz - 20 amp (standard)    230V - 3 ph - 60 Hz - 15 amp (optional)**

Ongoing quality improvements and design modifications may change specifications listed in this manual without notice

## **TOOLS REQUIRED and PRE INSTALLATION PROCEDURES**

**Tools Required:** Gather all the tools listed below.

- 4" x 4" Wooden Blocks (for unpacking)
- 16ft. Measuring Tape
- Chalk Line and Chalk
- Side Cutters
- Crow Bar
- Metric Wrenches and Ratchet Set
- SAE Wrenches and Ratchet Set
- Metric and SAE Allen Key Sets
- Hammer
- Screwdrivers
- 12 ft. Step Ladders - 2  
(2 people using 12 ft. ladders should install the overhead crossmember assembly)
- 4 ft. Levels - 2
- Rotary Hammer Drill with 3/4" diameter Masonry Drill Bit

### **Pre Installation Procedures**

Before proceeding with installation, read the installation manual and insure all instructions are fully understood and all component parts are accounted for.

1. In the installation area, identify the center line of the bay and mark the floor. Also mark the center of bay entrance door. Connect these two points with a short chalk line in the area where lift will be located. Draw a second chalk line at 90° to locate the positions of both lift columns (refer to lift dimensions and bay layout on page 6). Insure each lift column is equal distance from bay centerline and each baseplate maintains a minimum distance of 6 inches from any floor seam. Do not install if floor has cracks or deterioration that could affect lift stability. The shop owner is responsible for confirming there are no obstructions in the installation area like floor drains, under floor piping or electrical conduit that could be damaged or prevent safe lift installation and secure lift anchoring. Check ceiling for beams or heating ducts and walls for protruding structures, etc.. Model TLS210SRR 1/3 has two possible overall heights - 148½ inches or 138½ inches. Model TLS210SXR 1/3 has an overall height of 172". Confirm that the overall height you intend to install will fit in the bay. Insure that the lift can be safely installed in the position you have marked out on the bay floor.
2. Place the lift on wooden blocks so that the steel shipping frames can be removed.
3. Remove protective wrapping. Clear installation area of all packaging materials.
4. Unbolt steel shipping frames and remove from installation area.
5. Carefully remove top column and lay on the floor (carriage side up).
6. Carefully remove column extensions (2 pc), cross-member (3 pc), overhead safety bar, arms (4 pc), powerpack and hardware box from the lower column.
7. Identify powerpack column (reference diagram #1). Move (carriage side up) to appropriate location placing the baseplate end on your floor marks. Similarly, move the second column to the opposite location.



## **INSTALLATION PROCEDURE**

See the Installation and Parts Reference section of this manual for diagrams and parts lists that will assist you during the installation process (pages 15 – 26). Use these diagrams and parts lists together with the following written instructions. Insure the lift installation complies with ANSI/ALI/ALIS, Safety Requirements for Installation and Service of Automotive Lifts.

1. With columns laying on the ground (carriage side up), tightly fasten one column extension to one column using bolts, washers and nuts provided (reference diagram #1). Use the appropriate bolt hole locations to achieve either a 148½ inch or 138½ inch overall height. Repeat this procedure with second column. Note: Model TLS210SXR1/3 has a 172" overall height.
2. Layout all pieces of the overhead crossmember on the floor and fasten tightly together using bolts, washers and nuts provided (reference diagram #2).
3. Identify all parts for overhead safety shut-off bar (reference diagram #2). Tightly fasten these parts to overhead crossmember with bolts, washers and nuts provided.
4. Raise (stand up) each column so that its baseplate is located on the floor marking you made earlier. Confirm that baseplate angles and measurements between columns match lift specifications on page 5. **Use extreme caution to insure the columns do not fall over.** Secure baseplate of the most level column by installing one only anchor bolt.
5. For optimum safety, two installers should lift and secure the overhead crossmember to both columns using bolts, washers and nuts provided (reference diagram #2). Hand tighten all crossmember nuts and bolts. Final tightening is completed in step 9.
6. Using two 4 ft. levels and required shims, level each column vertically on all four sides (reference diagram #3). **Use extreme caution to insure the columns do not fall over. IMPORTANT:** When leveling each column using anchor bolts provided, do not use more than ¾ inch (19 mm) of shims under any area of the baseplate. Use a 4 ft. level to confirm the overhead crossmember is also level and at 90 degrees to both columns.
7. Drill and install all anchor bolts, washers and nuts (reference diagram #3). Insure that each nut is torqued to 150 ft-lbs (204Nm). ***This should be checked monthly.***
8. One equalizing cable comes partially installed on each carriage. Before feeding a cable up its column to the overhead crossmember, insure the cable is properly seated around the lower pulley at the base of each column (reference diagram #4). Route each cable up its column, over the appropriate pulleys in the overhead crossmember, and lower it down to the opposite carriage. Insure both equalizing cables are properly seated in overhead crossmember pulleys. Thread one nut to its farthest point on each equalizing cable. Insert threaded end into appropriate location on the carriage. Install and hand tighten second nut to secure each cable. Final equalizing cable adjustment is step 17. Install two bolts and nuts to prevent unintentional cable displacement (reference diagram #4).
9. Completely tighten both sides of the overhead crossmember to its column.
10. Identify component parts for the safety release cable (reference diagram #5). Install safety release cable so that safety locks in both columns will completely disengage when lift is lowered. Final safety release cable adjustment is step 16.
11. Identify parts to install arms (reference diagram #6). Install all 4 arms and arm pins. Secure each arm pin by inserting roll pin provided. Arm restraint adjustment is step 16.
12. Install rubber mounts on powerpack bracket (reference diagram #7). Keeping these rubber mounts between the powerpack and the mounting bracket, securely fasten powerpack to the mounting bracket.

**installation procedure continued on page 10 .....**

13. Identify parts for hydraulic system installation (reference diagram #7). Tightly fasten hydraulic lines to "T" fitting. Locate "T" assembly in overhead crossmember and route the appropriate lines to cylinders and powerpack. Tightly fasten all hydraulic lines and secure these lines to both columns and overhead crossmember using hardware provided (7 positions - reference diagram #7). Insure that nothing will rub or wear the hydraulic lines.
14. Attach microswitch to overhead safety bar bracket on powerpack side of overhead crossmember. Install carriage upper limit microswitch on power side column extension (use lower 4 holes for 138½" height and upper 4 holes for 148½" and 172" height – see diagram #8). **NOTE: the following three procedures should be performed by a certified electrician.** Wire overhead safety bar micro-switch and upper limit microswitch to the powerpack. Wire powerpack to shop electrical system.
15. Fill powerpack reservoir with ISO 32 hydraulic oil.
16. **Operate the lift with no vehicle and no other weight.** Raise lifting carriages approximately 30 inches. Confirm that safety locks on both sides engage properly while lift is being raised. Verify that both lifting cylinders are properly seated in the baseplate locator hole. Continue raising lift to full height confirming safety locks are engaging. Adjust safety release cable to insure safety locks can be completely disengaged while lowering lift (reference diagram #5). Insure that no people or obstacles are near the lift when adjusting the safety release cable. Lower lift completely. Raise and lower the lift at least three times or until all air in the hydraulic system is removed.
17. After confirming that all air has been bled from the hydraulic system, adjust equalizing cable tension as follows: (also reference diagram #4)

(Step 1) Hold top of threaded stud with a wrench to prevent it from rotating.

(Step 2) Tighten nut "B" until all loose slack is removed from the cable. Do not over tighten.

(Step 3) Firmly tighten nut "A" to lock cable in place. Repeat this process for the other cable insuring both cables have the same degree of tightness.

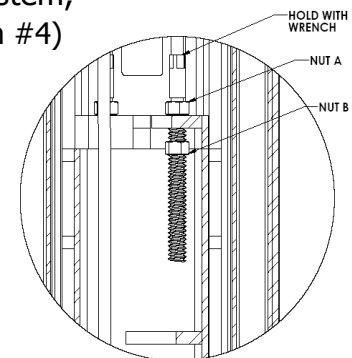

18. Raise lifting carriages approximately 12 inches off the floor. Choose one arm and align arm restraint gear with locking plunger insuring both components mesh smoothly and totally (reference diagram #6). Completely tighten all arm restraint gear locking bolts to maintain this position. Lower carriage to the floor to insure arm restraint disengages in the down position. Raise the lift 12 inches off the floor to insure arm restraint engages smoothly and totally. Repeat this process with the remaining 3 arms. Raise and lower the lift once more to confirm all arm restraints totally engage and disengage smoothly.

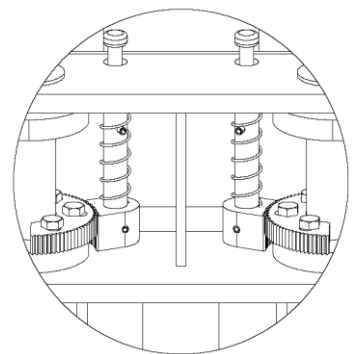

19. Install safety lock cover on each column (reference diagram #9).
20. To avoid damage, safety instruction and information decals are not applied at the factory but shipped with the lift. The ALI - WL101 Series Label Kit must be applied to lift columns before the lift is used (reference diagram #10). **Insure that all lift operators are trained in all points covered by this label kit.**

**Insure this manual along with all operation, inspection and maintenance instructions are delivered to the owner/user/employer**

## Final Checkout Procedure of Assembled Lift

- ✓ Check hydraulic oil level in reservoir. Confirm hydraulic connections are tight with no leaks
- ✓ Confirm that both columns are level and properly shimmed with all anchor bolts torqued to 150 ft.-lbs. (204Nm). Confirm lift stability
- ✓ Confirm that all electrical components have been wired properly and are operational
- ✓ Confirm that all cables are adjusted properly
- ✓ Confirm safety locks and arm restraints are functioning properly
- ✓ Lubricate all lubrication points

## OPERATING INSTRUCTIONS and LIFT MAINTENANCE

**LIFT OPERATION:** Before lifting a vehicle, insure all operators are qualified, have been trained and are following all safety instructions. Read and follow the ALI "Lifting It Right" manual included with the lift. **Always** use the "Vehicle Lifting Points" reference guide when lifting a vehicle (CD included with the lift). Insure all materials stay up to date >>> [www.autolift.org/](http://www.autolift.org/) (see example of SAE J2184 standard below)

**Insure the vehicle is securely positioned on the lift using manufacturer's recommended lifting points. Insure all arm restraints are totally engaged. Never allow anyone under the lift when raising or lowering it with or without a vehicle. Always confirm safety locks on both sides of the lift are completely engaged before proceeding under a vehicle.**

Lift electrical operating controls are located on the powerpack (one "up" button for raising the lift and one "down" lever for lowering the lift). Before lowering, slightly raise the lifting carriages to release pressure from both safety locks. Two hands must be used when lowering the lift. One hand must operate the safety lock release lever (located on the column above the powerpack) and one hand must operate the "down" lever. Make certain the safety locks do not accidentally re-engage while lift is being lowered. Customers and bystanders should not be in the lift area.

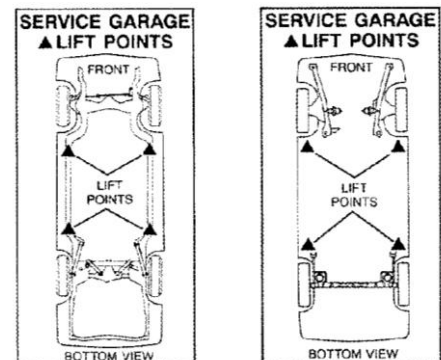

Typical Label Drawings  
Reprinted with permission from SAE J2184  
©2000 Society of Automotive Engineers, Inc.

**LIFT MAINTENANCE :** Before maintaining, servicing or repairing the lift, insure that an acceptable "lock out/tag out device is activated.

The following minimum maintenance schedule must be performed by the owner and/or lift operator:

- DAILY:**
- Raise and lower the lift (with no vehicle) at the beginning of each shift to verify it is operating properly and carriages are level. Confirm all arm restraints engage and disengage smoothly and totally and telescoping arms have no excessive movement.
  - Check all hydraulic fittings and lines for damage or leaks. Check electrical wiring for damage. Check all moving parts for uneven or excessive wear. Repair or replace all damaged, worn, or broken components immediately.
  - Remove oil/grease on all lift pads. ... **lift maintenance continued on page 12 ...**

WEEKLY: - Check hydraulic fluid in powerpack reservoir. (confirm no leaks before topping up )  
- Check equalizing cable adjustment. Check safety lock release cable adjustment.

MONTHLY: - Check that all anchor bolts are torqued to 150 ft-lbs (204Nm).  
- Clean and lubricate arm restraints. (confirm all components are in good condition)  
- Lubricate safety locks in both columns.  
- Check that overhead safety shutoff is operating properly.

EVERY TWO MONTHS: - Remove and grease arm pins – reinstall insuring secure fit.  
- Clean and re-grease slide block channel in both columns.  
- Clean and lubricate all cable pulleys.

EVERY YEAR: - Arrange for a Trained Lift Service Person to inspect and certify all aspects of the lift as per "Automotive Lift Operation, Inspection and Maintenance" (ALOIM) guidelines. Confirm that both equalizing cables meet the standard outlined on page 13

EVERY TWO YEARS: - Change and replace hydraulic oil in cylinders and powerpack.

Lubrication Specifications: - where grease is required use a multi-purpose lithium grease  
- where lubricating oil is required use WD-40 or a SAE 30 oil  
- where hydraulic oil is required use ISO 32 – 10W non detergent hydraulic oil.

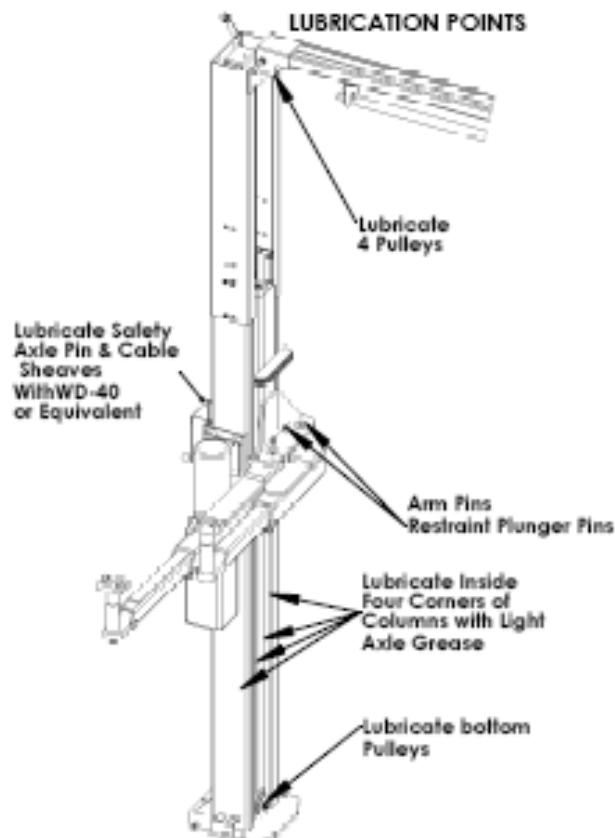

**lift maintenance continued on page 13 .....**

**The following criteria will determine when an equalizing cable is no longer acceptable for service:**

- 12 randomly distributed broken wires in one lay or four broken wires in one strand in one lay in running ropes
- one outer wire broken at the contact point with the core of the rope, which has worked its way out of the rope structure and protrudes or loops out from the rope structure
- wear of one-third the original diameter of outside individual wires
- kinking, crushing, birdcaging, or any other damage resulting in distortion of the rope structure
- evidence of heat damage from any cause
- reduction from nominal diameter greater than those listed in the following table:

<b>Rope Diameter (inch)</b>	<b>Maximum allowable reduction from Nominal Diameter (inch)</b>
Less than or	1/64
More than 5/16	1/32
More than 1/2 to	3/64

**Note:** Attention shall be given to end connections. Upon development of two broken wires adjacent to socket end connections, the rope shall be resocketed or replaced. Resocketing shall not be attempted if the resulting rope length will be insufficient for proper operation.

## **LIFT PROBLEM TROUBLESHOOTING GUIDE**

The following are some suggestions to consider if problems are encountered with the lift. Please call a Trained Lift Service Person for further clarification and information.

1. Lift does not operate:  
Possibilities include - blown fuse or tripped circuit breaker – tripped thermal overload on motor – defective "up" button. Call a qualified electrician for all wiring questions.
2. Motor runs but lift does not rise:  
Possibilities include – low hydraulic oil level (check reservoir tank) - dirt under check valve (press "down" lever and "up" button at the same time for 10-15 seconds. This will clear small contaminants. If this fails clean check valve ball and seat by removing valve cover). Call a Trained Lift Service Person if problem continues.
3. Motor noise (drone or hum) but will not run:  
Possibilities include – low voltage, faulty wiring or faulty capacitor (call electrician to confirm) – lift is overloaded (insure vehicle weighs less than rated lift capacity).
4. Lift falters or jerks when it is raised or lowered:  
Possibilities include – air in the hydraulic system (cycle lift all the way to the top and completely lower 3 – 4 times. If this does not solve the problem call a Trained Lift Service Person.
5. Excessive noise when raising or lowering lift:  
Possibilities include – pulley assemblies need lubricating – cable is off the pulleys – carriage sliders need grease – carriage sliders are broken. Do not operate the lift with broken or damaged carriage sliders or dislodged cable. Replace immediately.
6. Lifting carriages are unequal when raised:  
Possibilities include – improperly adjusted equalization cables – air in the hydraulic system. Adjust cables or call a Trained Lift Service Person to correct the problem.

**Replace all worn or broken parts and components only with manufacturer approved/supplied parts and components**

**Replacement parts may be purchased from your local lift supplier or the manufacturer at 1 - 877 - 799 - LIFT (5438) or (905) 847 - 1198**

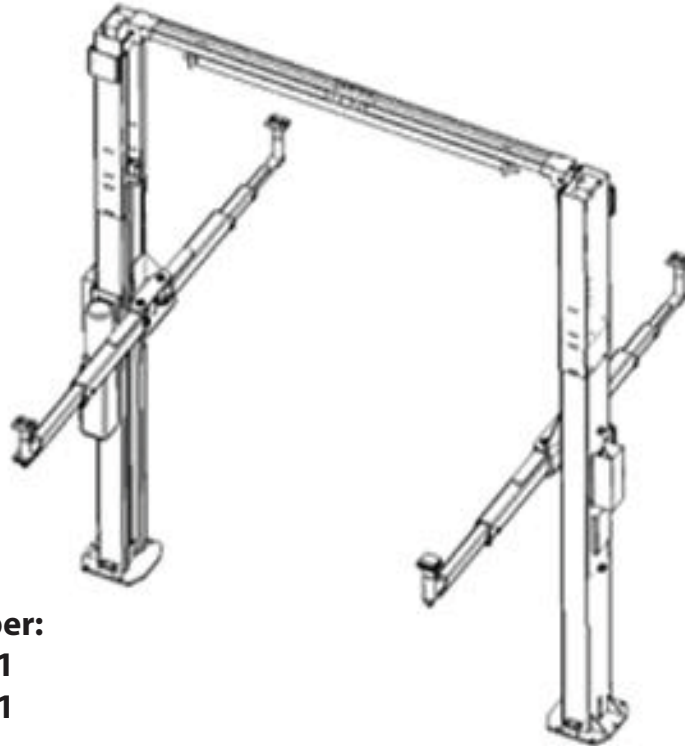

**Model Number:**  
TLS210SRx1  
TLS210SXx1

10,000 lb (4,536 kg) MultiMetric Two Post

# Lift Illustrations & Parts Lists

for installation & service part reference  
SAVE this MANUAL and ALL INSTRUCTIONS

Total Automotive Lifting Solutions Inc.  
2300 Speers Rd. Oakville, Ontario L6L 2X8  
Phone: (905) 847-1198 Fax: (905) 891-1214  
www.TLSLifts.com

Part Number: D -TP -10 -MM  
Issue 00 5 Effective : May 1, 200 9  
Supersedes Issue 00 4 - April 15, 200 9

## LIFT ILLUSTRATIONS and PARTS LISTS

The diagram below identifies main component parts and the order in which they are to be installed. Numbers correspond to installation diagrams found in the chart below and on following pages. Page numbers for each diagram is also found in the chart below. These diagrams, along with related parts lists, will assist you when installing and servicing this lift. Please insure these lift diagrams and parts lists are kept in a secure place for quick reference.

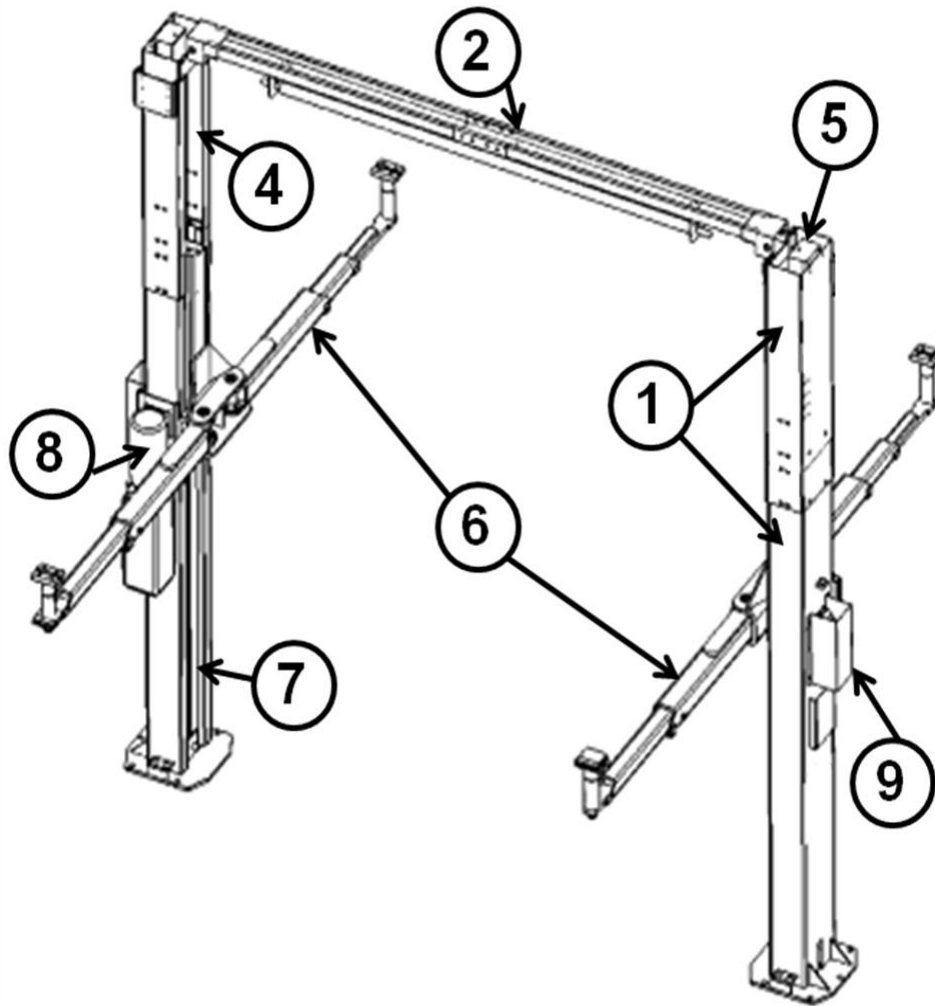

<u>Diagram Number</u>	<u>Diagram Description c/w Parts Lists</u>	<u>Page Number</u>
1	Lift Columns and Column Extension Assembly	17
2	Overhead Crossmember - Safety Shutoff Bar with Microswitch	18
3	Lift Leveling - Column Shimming - Anchor Bolt Installation	19
4	Equalizing Cable Installation	20
5	Safety Release Cable Installation	21
6	Lift Arm and Arm Restraint Installation	22
7	Hydraulic System	23
8	Powerpack and Overhead Safety Bar Microswitch Wiring	24
9	Safety Dog Cover Installation	25
10	Safety Decal Installation	26



## **Diagram #1 : LIFT COLUMNS AND COLUMN EXTENSIONS**

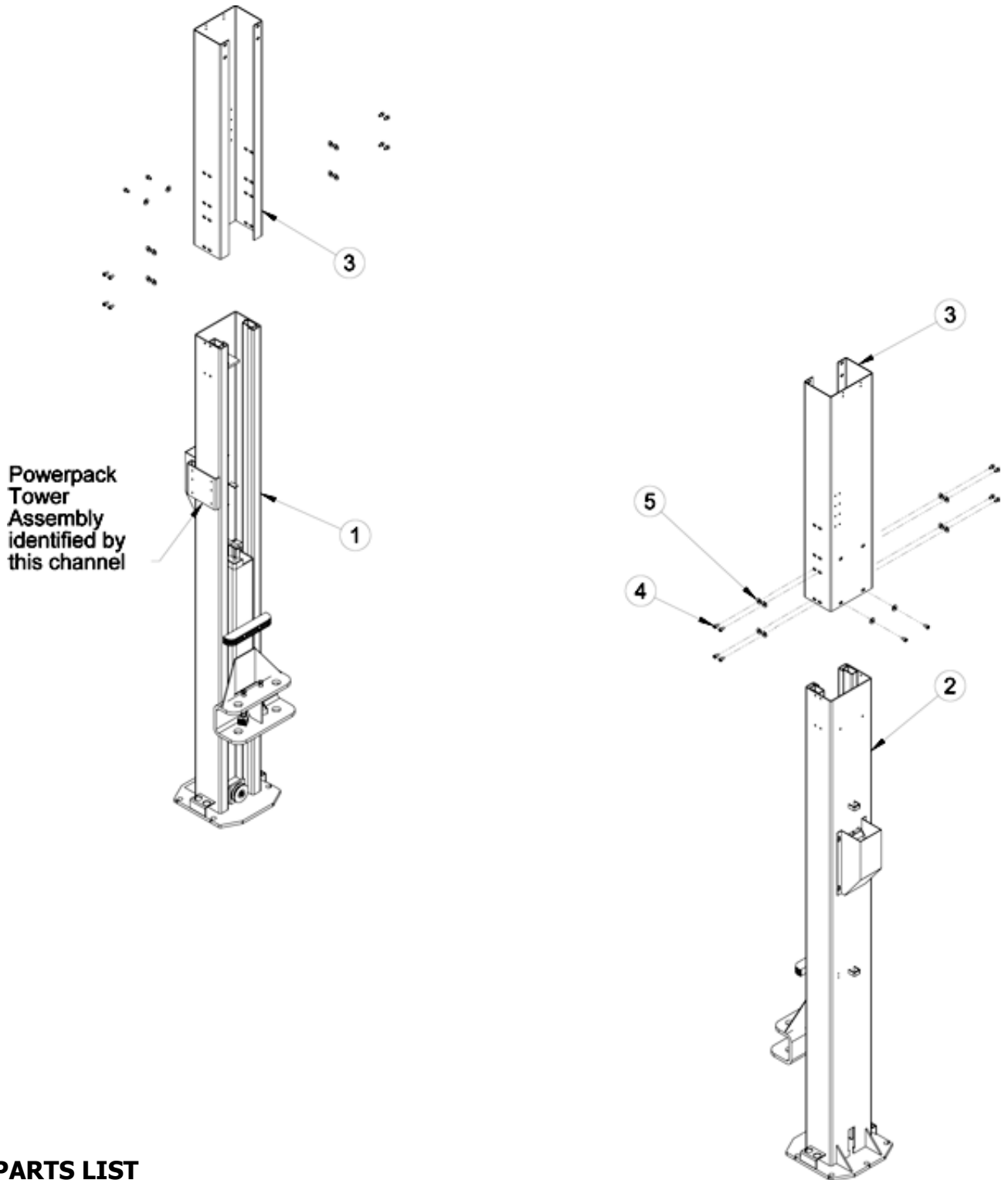

### **PARTS LIST**

Item	Part Number	Description	Qty
1	22100031	Powerpack Tower Weldment	1
2	22100032	Opposite Tower Weldment	1
3	12100016	Standard Tower Extension	2
4	32100010	Hex Socket Cap Screw - M10 x 10	20
5	32100036	Spring Lock Washer - M10	20

## Diagram #2 : OVERHEAD CROSSMEMBER ASSEMBLY

(includes safety shutoff bar and equalizing cable pulleys)

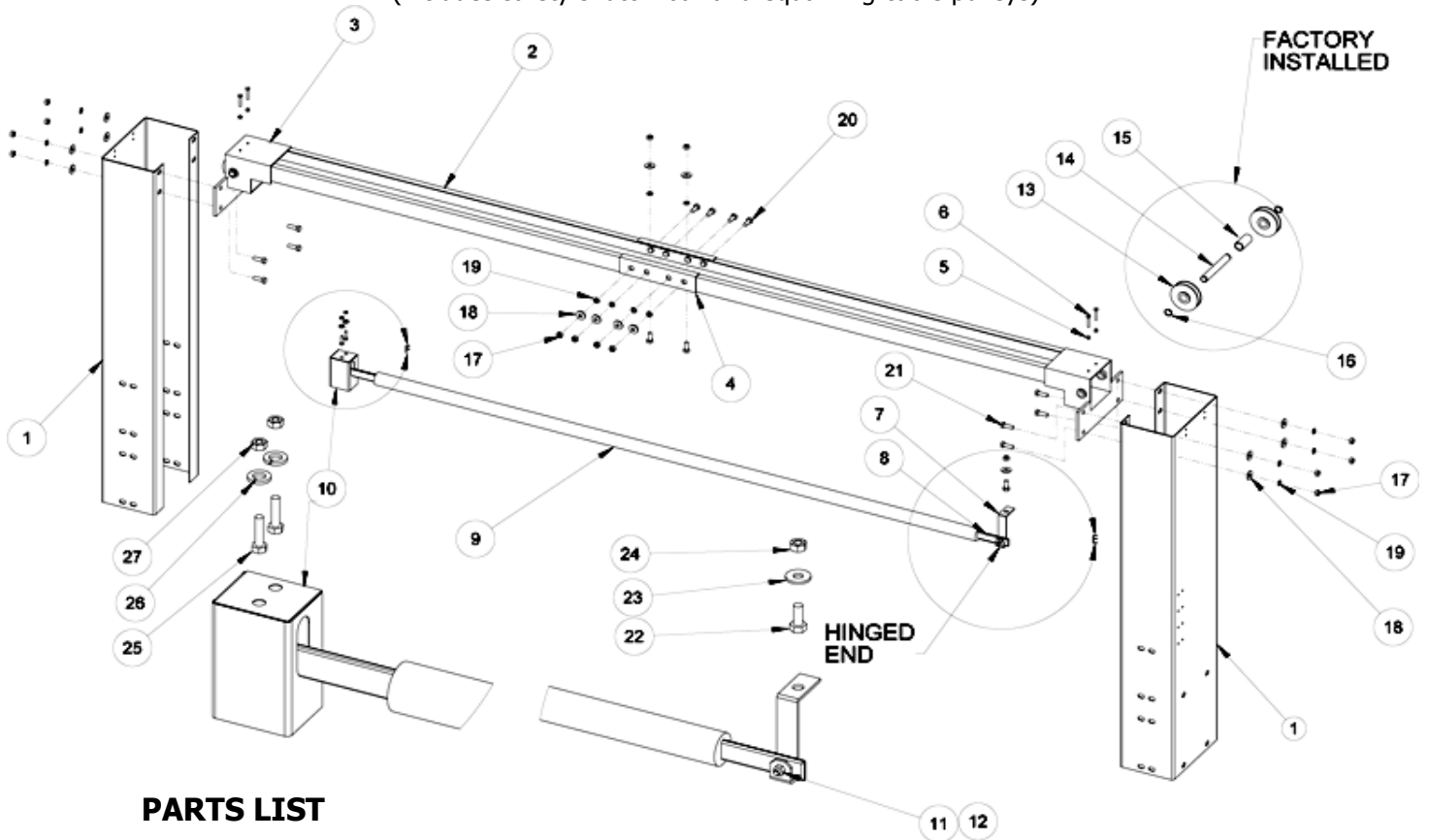

### PARTS LIST

Item	Part Number	Description	Qty
1	12100016	Standard Tower Extension	2
2	12100094	Overhead Crossmember Channel	2
3	12100588-1	Symmetric Channel Bracket	2
4	12100095	Overhead Channel Brace	1
5	32103035	Equalizing Cable Retainer Bolt M6 x 35	8
6	32103036	Nut M6	8
7	12100102	Overhead Shut-off Mounting Bracket-Left	1
8	12100111	Overhead Shut-Off Bar	1
9	12100103	Overhead Shut-Off Foam Guard	1
10	42100010	Overhead Shut-off Microswitch (Mount on Powerpack Side)	1
11	32103035	Hex Head Bolt M6 ???	1
12	32103036	Hex Nut M6 ???	1
13	12100098	Overhead Pulley	4
14	12100096	Pulley Spacer	2
15	32100034	External Retaining Ring 20MM	4
17	32100532	Hex Nut M10X1.5	16
18	32100506	Plain Washer 10MM	16
19	32100507	Spring Lock Washer 10MM	16
20	32100530	HHMS M10X1.5X25	8
21	32100531	HHMS M10X1.5X30	8
22	32100020	M8 x 1.25 x 16 Hex HSCS	1
23	32100044	10 mm Flat Washer	1
24	32100027	Hex Nut M8 x 1.25	1
25	32100025	Hex Cap Screw M6 x 1.0 x 25	2
26	32100026	Spring Washer	2
27	32103026	Hex Nut M6 x 1.0	2

**Diagram #3 : LIFT LEVELLING - COLUMN SHIMING - ANCHOR BOLTS**

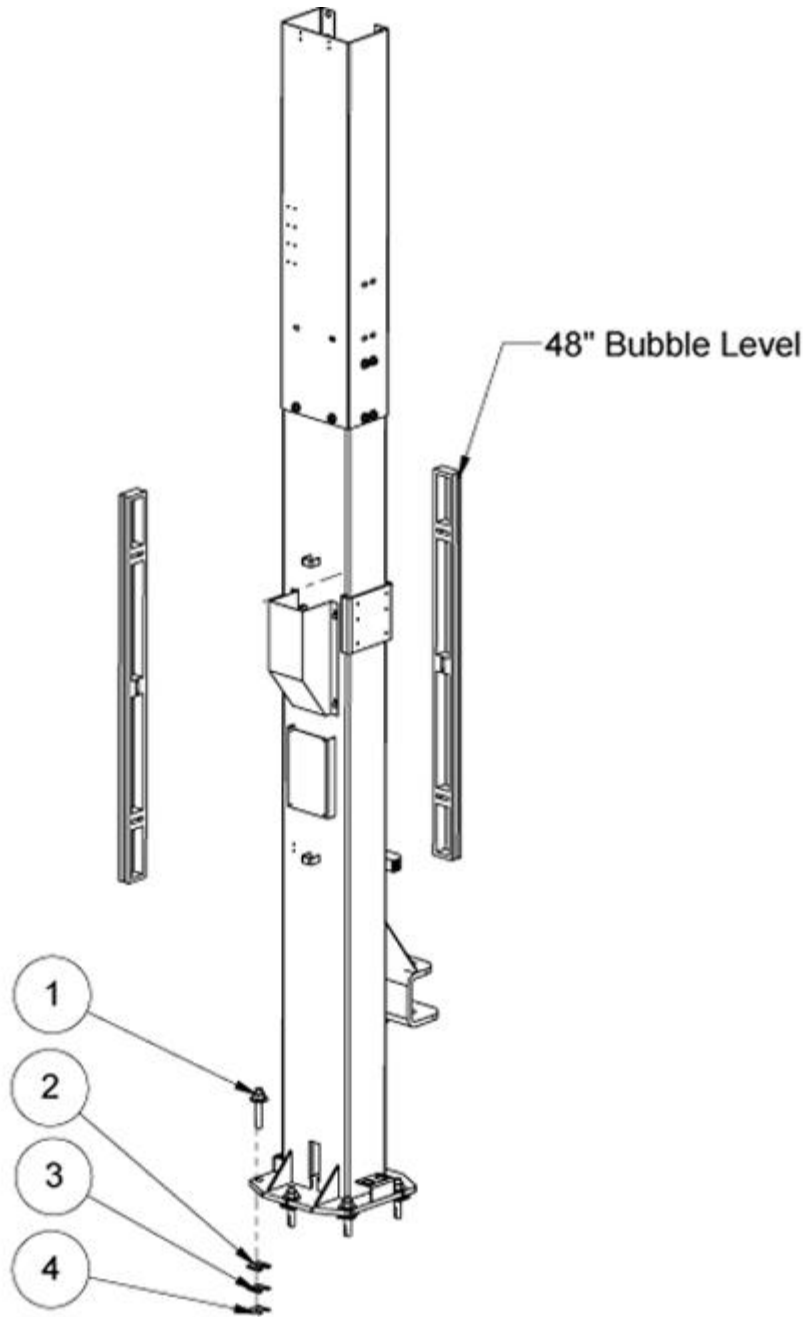

**PARTS LIST**

Item	Part Number	Description	Qty
1	3000539	3/4"x5" Concrete Anchor	10
2	3000540	Shim-6mm	10
3	3000541	Shim-3mm	10
4	3000542	Shim-1mm	10

## Diagram #4 : EQUALIZING CABLES

TO PREVENT PULLEY UNINTENTIONAL DISPLACEMENT

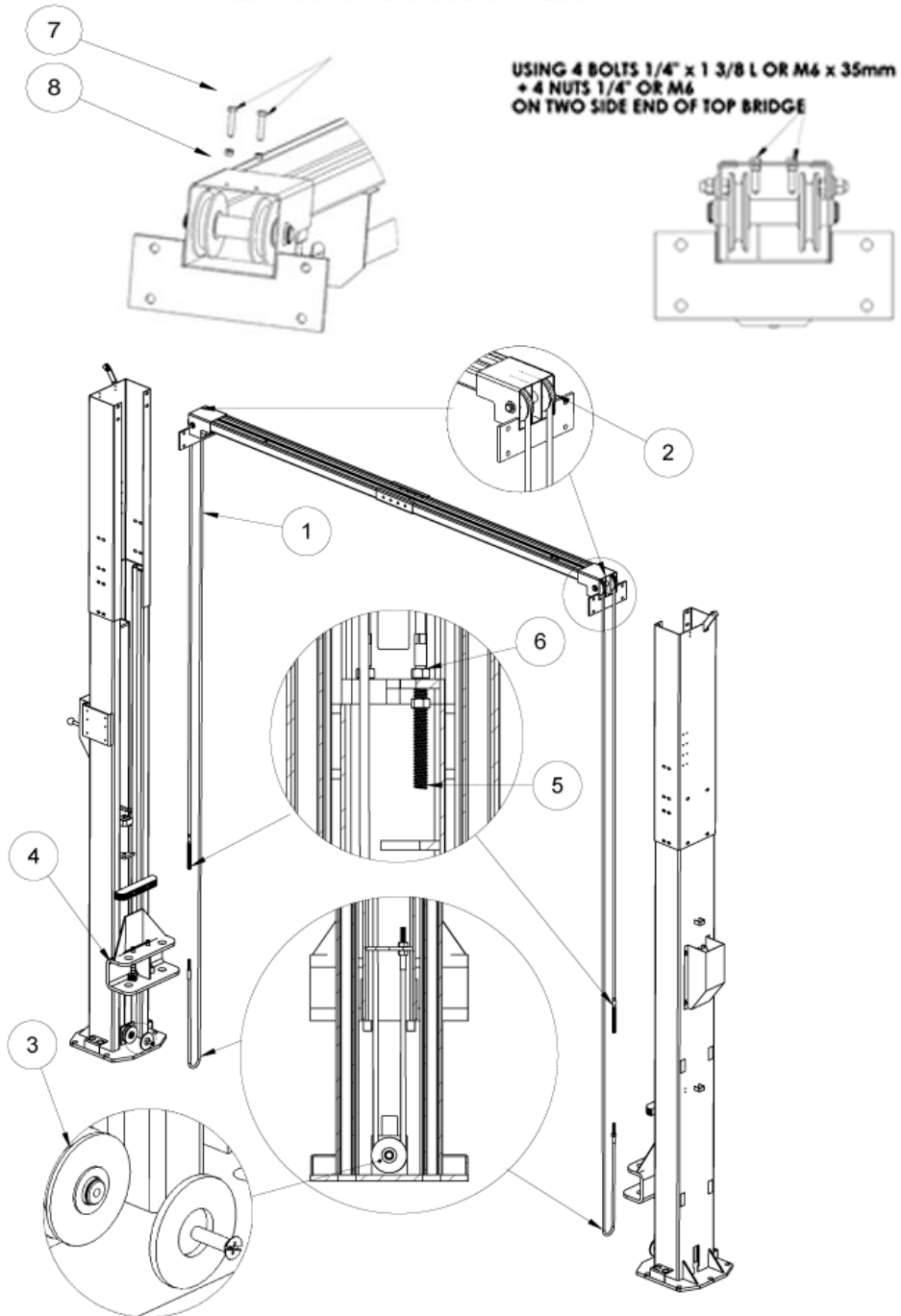

### PARTS LIST

Item	Part Number	Description	Qty
1	32100000	Equalizing Cable	2
2	12100098	Overhead Pulley	4
3	12100043	Equalizing Pulley	2
4	42100011	Carriage Assembly	2
5	32100591	Cable Stud 12 x 1.5	4
6	32100038	Heavy Hex Nut M12	8
7	32103035	1/4" x 13/8" or M6 x 35 mm Bolts	4
8	32103036	1/4" or M6 Nuts	4

**Diagram #5 : SAFETY RELEASE CABLE**

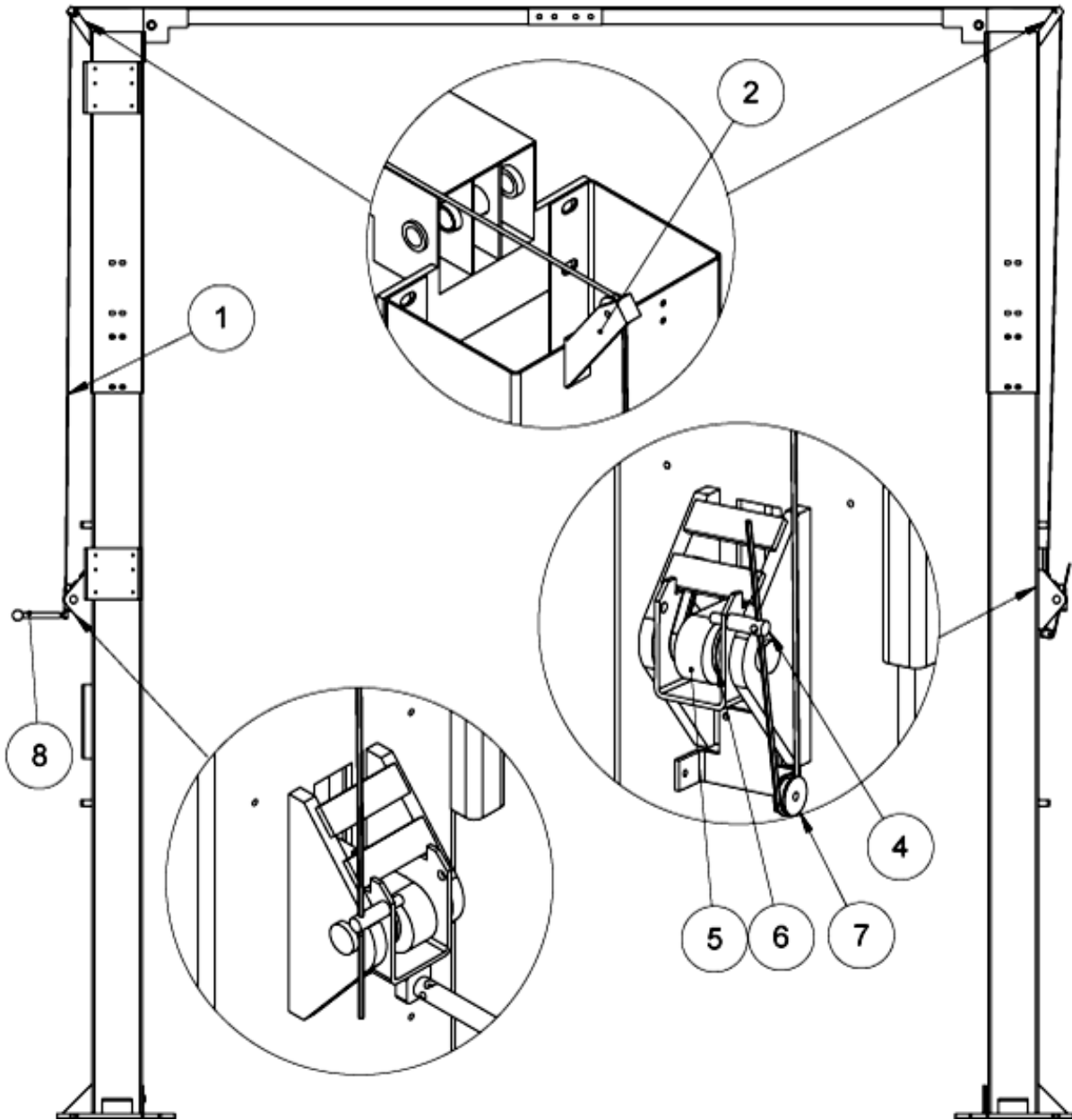

**PARTS LIST**

Item	Part Number	Description	Qty
1	32100001	Safety Release Cable	1
2	22100033	Safety Cable Guide Assembly	2
4	12100021	Safety Release Cable Clamp	2
5	12100086	Lock	2
6	12100078	Torsion Spring	2
7	12100044	Safety Pulley	1
8	12100025	Safety Release Lever	1

## Diagram #6

### Multi-Metric LIFT ARMS AND ARM RESTRAINTS

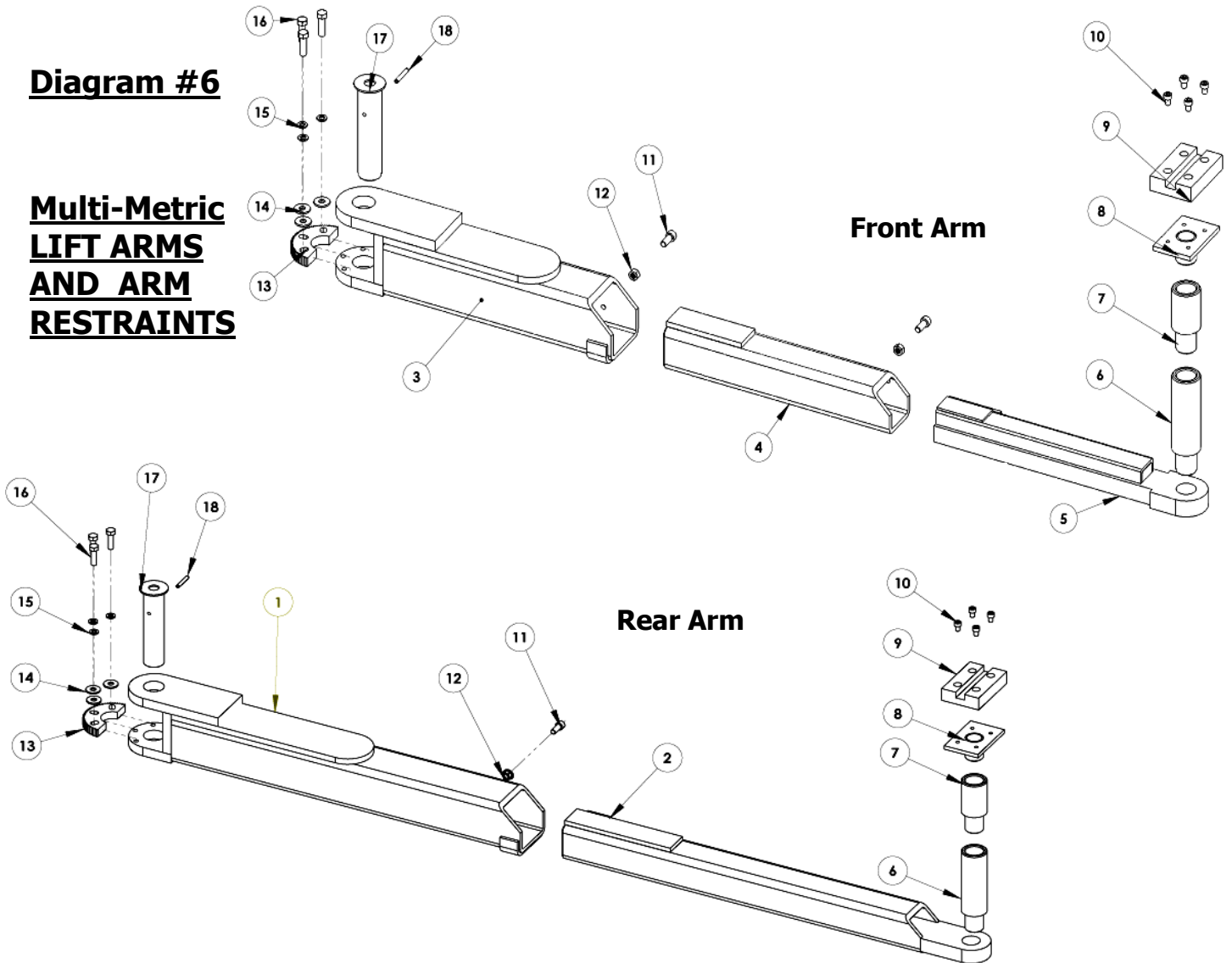

Item	Part Number	Description	Qty
1	22100026	Rear Outer Arm Weldment	2
2	22100024	Rear Inner Arm Weldment	2
3L	22103020	Left Front Outer Arm Weldment	1
3R	22103021	Right Front Outer Arm Weldment	1
4	22103019	Front First Inner Arm Weldment	2
5	22103017	Front Second Inner Arm Weldment	2
6	12100088	6 inch Stack Pad Adapter	4
7	12100090	3 inch Stack Pad Adapter	4
8	22100028	Stack Pad Weldment	4
9	12100049	Premium Rubber Stack Pad	4
10	32100020	M8x1.25x16 HEX SHCS	4
11	32100008	Hex Cap Screw M10X1.5X25	4
12	32100009	Hex Nut M10X1.5	4
13	12100050	Arm Restraint	4
14	32100036	Spring Lock Washer 10MM	12
15	32100035	Flat Washer 10MM	12
16	32100013	Hex Cap Screw M10X1.5X35	12
17	22100027	Arm Pin	4
18	32100006	Spring Lock Pin 6MMX40MM	4

## **Diagram #7 : HYDRAULIC SYSTEM**

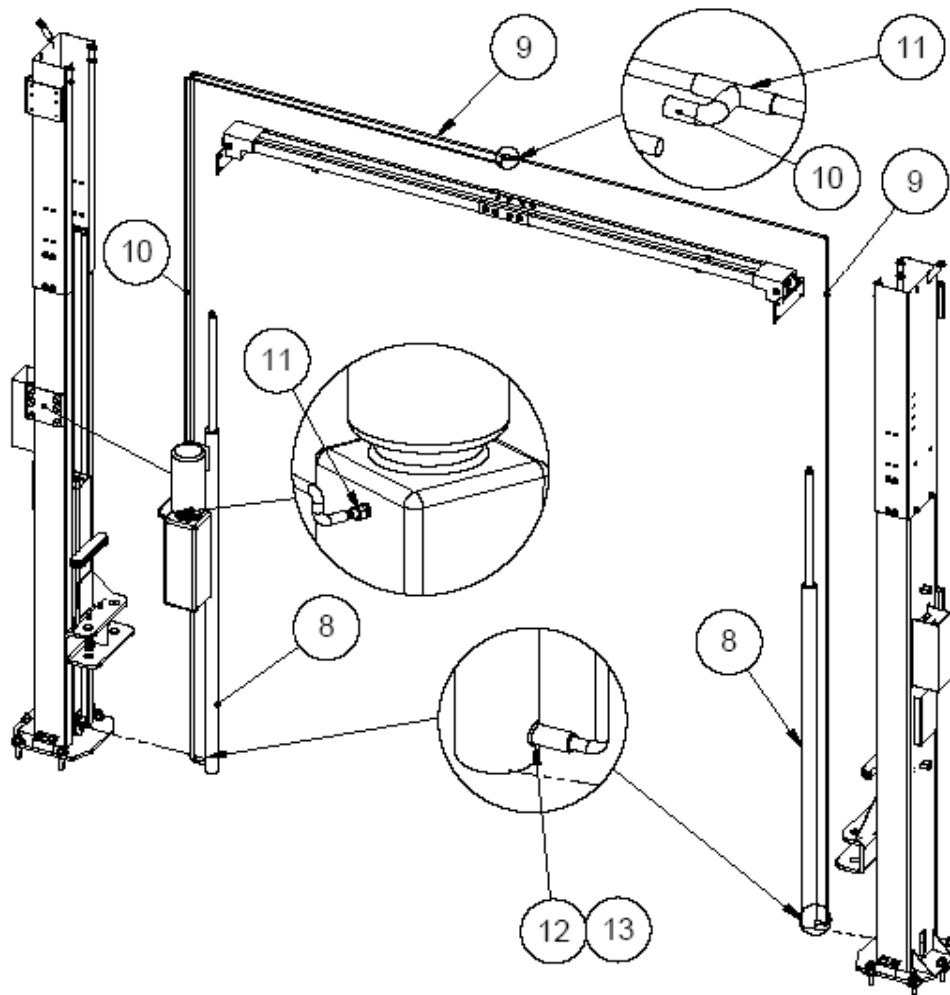

### **HYDRAULIC HOSE TIE DOWN LOCATIONS**

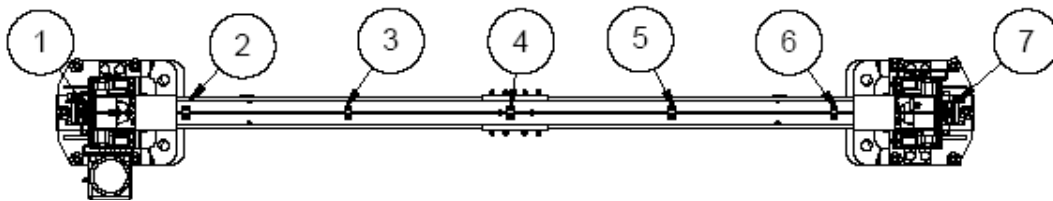

### **PARTS LIST**

Item	Part Number	Description	Qty
1 - 7		Hydraulic Hose Cable Tie Positions	7
8	42104007	Hydraulic Cylinders	2
9	32100046	Hydraulic Hose Long (Straight Fitting)	2
10	32100047	Hydraulic Hose Short (90 Degree Fitting)	1
11	32100048	T-Fitting	1
12	32100049	Cylinder Straight Fitting	2
13	32100050	Restrictor Block	2

**Diagram #8 : POWERPACK AND OVERHEAD SAFETY BAR  
MICROSWITCH WIRING**

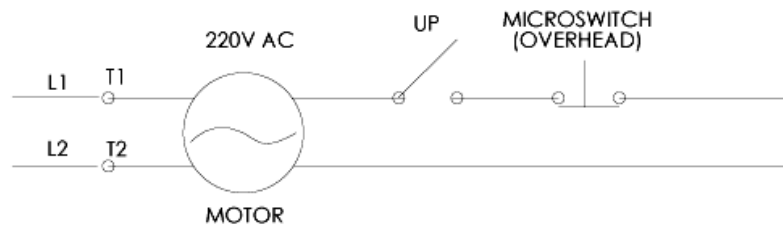
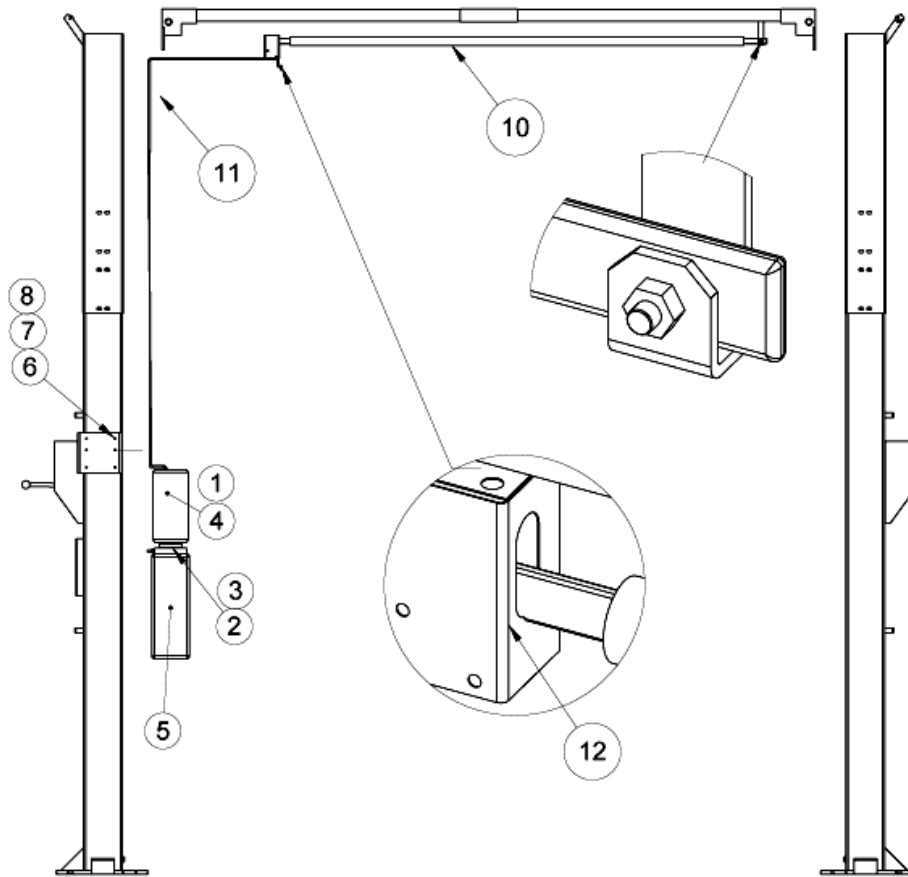

**PARTS LIST**

Item	Part Number	Description	Qty
1	32100041	Button	1
2	32100042	Handle	1
3	32100043	Relief Valve	2
4	32100044	Motor	1
5	32100045	Tank	1
6	12100541	Power Unit Mounting Rubber (with M8 Stud)	4
7	32100522	Flat Washer 8MM	4
8	32100524	Hex Nut M8	4
10	42104004	Overhead Safety Assembly (11 pc)	1
11	52100002	Microswitch Wiring	2
12	42100010	Microswitch Safety Box / Limit Switch	1



## **Diagram #9 : SAFETY LOCK COVER INSTALLATION**

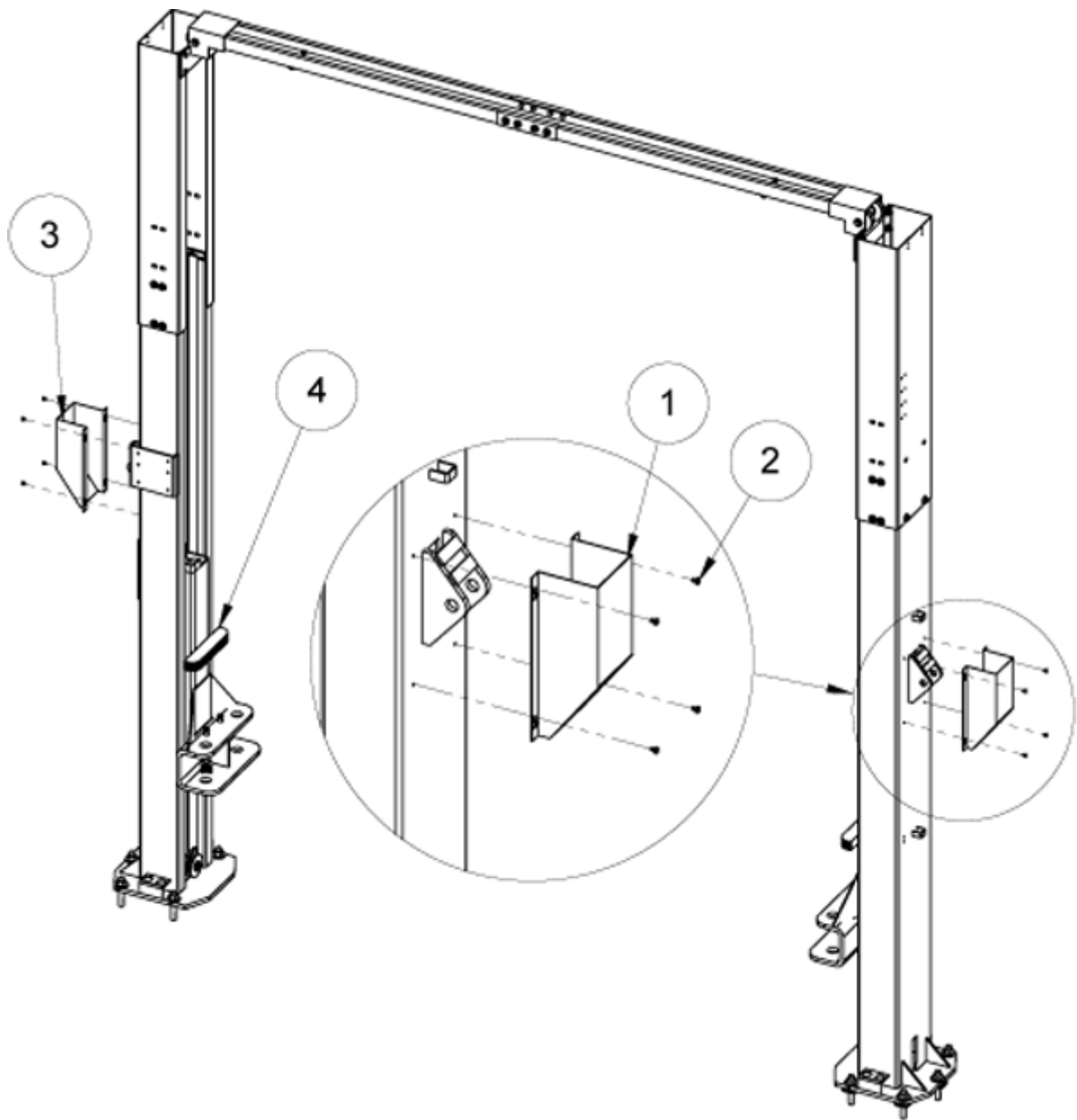

### **PARTS LIST**

Item	Part Number	Description	Qty
1	12100547	Safety Cover – Passenger Side	1
2	32100024	Round Head Screw M6x1.0x10	8
3	12100548	Safety Cover – Driver Side	1
4	12100084	Door Guard	2

# Diagram #10 : SAFETY INSTRUCTION and INFORMATION DECAL KIT APPLICATION

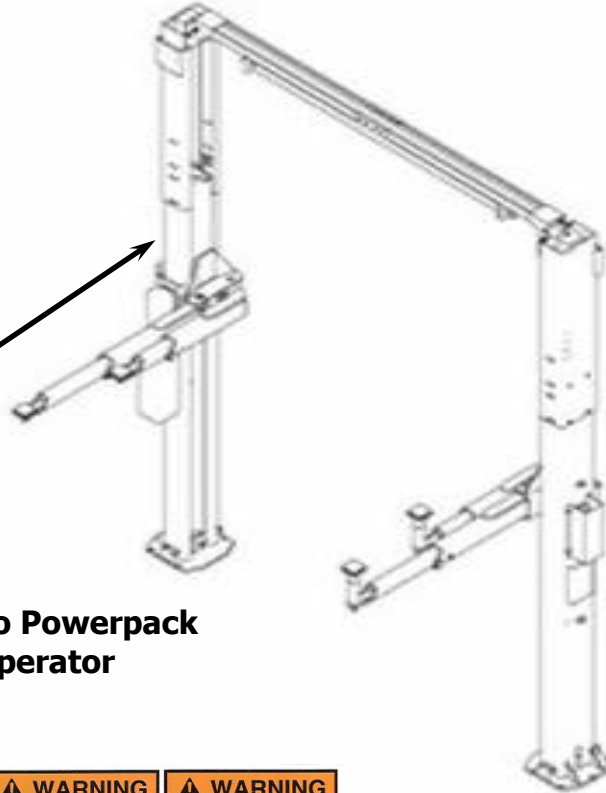

Apply Individual Decals to Powerpack Column in clear view of operator

<p><b>CAUTION</b></p> <p>Lift to be used by trained operator only.</p>	<p><b>CAUTION</b></p> <p>Authorized personnel only in lift area.</p>	<p><b>WARNING</b></p> <p>Clear area if vehicle is in danger of falling.</p>	<p><b>WARNING</b></p> <p>Position vehicle with center of gravity midway between adapters.</p>
<p><b>CAUTION</b></p> <p>Use vehicle manufacturer's lift points.</p>	<p><b>CAUTION</b></p> <p>Always use safety stands when removing or installing heavy components.</p>	<p><b>WARNING</b></p> <p>Remain clear of lift when raising or lowering vehicle.</p>	<p><b>WARNING</b></p> <p>Avoid excessive rocking of vehicle while on lift.</p>
<p><b>CAUTION</b></p> <p>Use height extenders when necessary to ensure good contact.</p>	<p><b>CAUTION</b></p> <p>Auxiliary adapters may reduce load capacity.</p>	<p><b>WARNING</b></p> <p>Do not override self-closing lift controls.</p>	<p><b>WARNING</b></p> <p>Keep feet clear of lift while lowering.</p>
<p>The messages and pictographs shown are generic in nature and are meant to generally represent hazards common to all automotive lifts regardless of specific style.</p> <p>Funding for the development and validation of these labels was provided by the Automotive Lift Institute, PO Box 85 Cortland, NY 13045.</p> <p>Replacement label sets may be obtained from the original lift manufacturer and ALI's member companies. They are protected by copyright.</p> <p>www.autolift.org ©1992 by ALI, Inc. ALIWL101c</p>		<p>The messages and pictographs shown are generic in nature and are meant to generally represent hazards common to all automotive lifts regardless of specific style.</p> <p>Funding for the development and validation of these labels was provided by the Automotive Lift Institute, PO Box 85 Cortland, NY 13045.</p> <p>Replacement label sets may be obtained from the original lift manufacturer and ALI's member companies. They are protected by copyright.</p> <p>www.autolift.org ©1992 by ALI, Inc. ALIWL101d</p>	

Also Apply to Powerpack Column in clear view of operator

<p><b>SAFETY INSTRUCTIONS</b></p> <p>Read operating and safety manuals before using lift.</p>	<p><b>SAFETY INSTRUCTIONS</b></p> <p>Proper maintenance and inspection is necessary for safe operation.</p>
<p><b>SAFETY INSTRUCTIONS</b></p> <p>Do not operate a damaged lift.</p>	<p>The messages and pictographs shown are generic in nature and are meant to generally represent hazards common to all automotive lifts regardless of specific style.</p> <p>Funding for the development and validation of these labels was provided by the Automotive Lift Institute, PO Box 85 Cortland, NY 13045.</p> <p>Replacement label sets may be obtained from the original lift manufacturer and ALI's member companies. They are protected by copyright.</p> <p>www.autolift.org ©1992 by ALI, Inc. ALIWL101s</p>