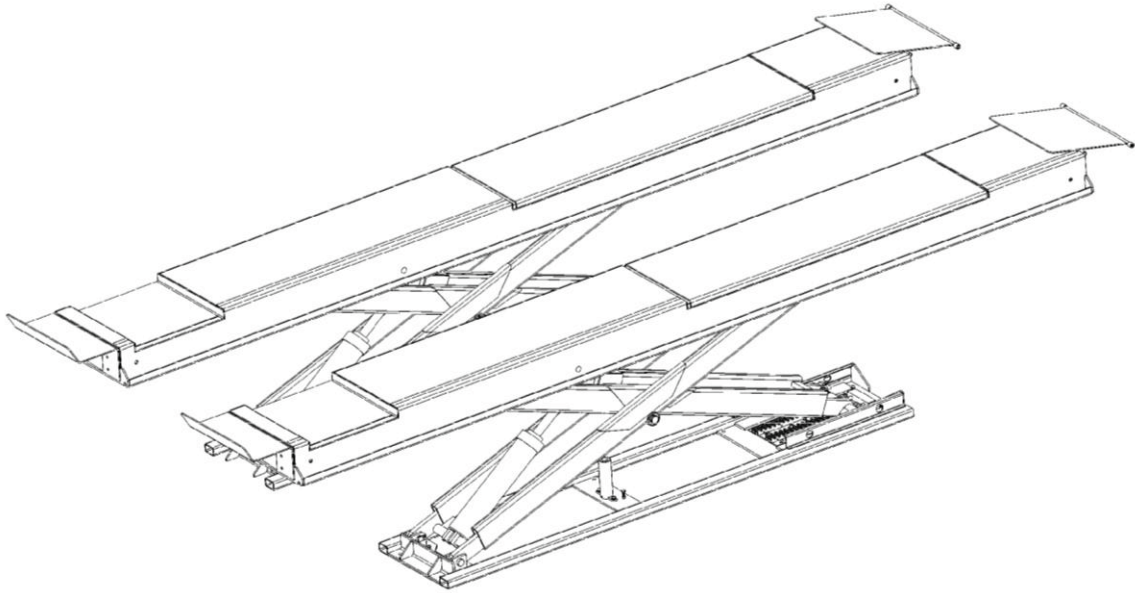


## TLS DOUBLE SCISSOR LIFT



14,000 lb. ( 6350 kg ) FLUSHMOUNT SCISSOR LIFT

Model TLSS14ALOFRR1

# Installation / Operation & Service Parts Manual

READ the Manual Thoroughly Before Installing,  
Operating, Servicing, or Maintaining the Lift

SAVE this MANUAL and ALL INSTRUCTIONS

Your new lift will provide years of dependable service if installed, operated and maintained properly. **Read and be prepared to follow all safety, installation, operation, and maintenance instructions in this manual before installing and operating the lift. In addition, read and follow all safety and other information included on and with the lift before operating the lift. Keep this manual in a secure place for future reference, training and service part identification.**

## **TABLE of CONTENTS**

1. Unloading Procedure and Lift Package Contents	page 3
2. Warranty and Safety	page 4 - 6
3. General Requirements and Lift Specifications	page 7 - 8
4. Pre Installation Procedures and Tools Required	page 9 - 10
5. Installation Procedures	page 10 - 12
6. Operating Instructions and Lift Maintenance	page 13 - 14
7. Troubleshooting	page 15
8. Lift Installation Diagrams and Parts Lists	page 16 - 30

**IMPORTANT** : It is the shop owner's responsibility to provide a satisfactory installation area for the lift. Lifts should only be installed in a "pit" with a minimum of 4 inches (102mm) / 3000 psi (20.7MPa) concrete that has been aged a minimum of 30 days. Please consult a qualified individual if any doubt exists concerning proper installation and subsequent safe operation of the lift. Do not install the lift on asphalt or outdoors. (see "pit" detail – page 8)

Prior to installation, it is the shop owner's responsibility to provide constant electrical power in the correct voltage, phase, etc., and all wiring for electrical hook-up of the lift. The shop owner must insure that the electrical installation conforms to local building and safety codes. Where required, the shop owner will provide an electrical isolation switch located in close proximity to the lift. This switch will have an emergency stop capability and isolate electrical power from the lift for servicing requirements.

Hydraulic oil cannot be shipped with the lift and will be supplied by either the shop owner or the installer. ISO 32 hydraulic oil (10W non detergent hydraulic oil) must be used to fill the reservoir tank before operating the lift. Grout for lift leveling must also be purchased locally.

**It is the shop owner's responsibility to train all operators in lift operation and lift safety.**

# **UNLOADING PROCEDURE and LIFT PACKAGE CONTENTS**

## **For your information:**

All lift components are packaged together in one module held together by steel bands

## **UNPACKING PROCEDURE:**

When the lift arrives on site:

- If possible have lift unloaded in the installation area
- Check for freight damage and report immediately to the trucking company who delivered the lift
- Check for missing parts and report immediately to the factory  
1 - 877 - 799 - LIFT (5438) or (905) 847 - 1198

## **Main Components include:**

Runway Assembly - labeled #1  
Runway Assembly - labeled #2  
Approach Ramps – 2pc  
Accessory and Hardware Box (see list below)

## **Optional Accessories: (included only if ordered)**

Rolling Air/Hydraulic Jacks - 1 jack per box c/w coiled air line  
Turnplates - 1 turnplate per box c/w retainer brackets

## **Accessory Box includes:**

Operator Console (power unit) – 1 pc  
Hydraulic Hose for Return Oil Line – 1 pc  
Air Hose for Safety Locks and Optional Rolling Jacks – 2 pc  
Approach Ramp Bracket and Pin – 2 pc  
Front Wheel Stops – 2 pc  
Hydraulic Line Covers - 4 pc  
Wheel Chocks – 2pc  
WL 200 Series Safety Information Label Kit  
ALI - " Lifting It Right " Manual  
ALI - " Vehicle Manufacturer's Lifting Point Guide" (CD)  
Automotive Lift Safety Tips Hang Card  
Automotive Lift, Operation, Inspection and Maintenance Manual  
Owner's Manual

**Hardware Box includes:** fittings, bolts, washers, nuts, anchor bolts, etc.

## **WARRANTY and SAFETY**

**Warranty:** The scissor lift model identified in this manual has the following warranty from date of purchase:

**Structural Components - 5 years**

**Hydraulic and Other Components - 1 year**

**Accessory Items - 90 days**

**Labor - 1 year**

The above items are warranted to be free of defects in material and workmanship to the original owner of the lift as follows: During the first year (90 days for accessories), those parts proven after inspection to be defective shall be repaired or replaced at the option of the manufacturer. Structural components only are warranted for an extended four years and if proven after inspection to be defective shall be repaired or replaced at the option of the manufacturer. This warranty does not extend to defects caused by ordinary wear, misuse, abuse, improper maintenance, shipping damage or where repairs have been attempted or made by anyone other than the manufacturer or a manufacturer certified technician. This warranty is exclusive and in lieu of all other warranties express or implied. In no event shall the manufacturer be liable for special, incidental or consequential damages for any breach or delay in performance of the warranty. The manufacturer reserves the right to change specifications, designs or add improvements to its product line without incurring any obligation to make such changes to products sold previously.

## **IMPORTANT SAFETY INSTRUCTIONS**

When using your garage equipment, basic safety precautions should always be followed, including the following:

1. Read all instructions
2. Care must be taken as burns can result from touching hot parts
3. Do not operate equipment with a damaged cord or if equipment has been dropped or damaged – until it has been examined by a qualified service person
4. Do not let a cord hang over the edge of the table, bench, or counter or come in contact with hot manifolds or moving fan blades
5. Let equipment cool completely before putting away. Loop cord loosely around equipment when storing
6. To reduce risk of fire, do not operate equipment in the vicinity of open containers of flammable liquids (gasoline)
7. Adequate ventilation should be provided when working on operating internal combustion engines
8. Keep hair, loose clothing, fingers, and all parts of body away from moving parts
9. To reduce the risk of electric shock, do not use on wet surfaces or expose to rain
10. Use only as directed in this manual. Use only manufacturer's recommended attachments
11. ALWAYS WEAR SAFETY GLASSES. Everyday eyeglasses only have impact resistant lenses, they are not safety glasses

## **SAVE THESE INSTRUCTIONS**

**safety cont'd on page 5**

## **Safety Continued**

Basic common sense safety precautions should always be followed when installing, operating and maintaining the lift as a risk of fire, electric shock, or injury may be present.

### **In addition:**

1. Read and follow all safety instructions and decals included with the lift. Read and follow all safety instructions in this manual. Read and follow the ALI "Lifting It Right" manual (included with the lift). Always use the "Vehicle Lifting Points" reference guide when lifting a vehicle (CD is included with the lift). Insure all materials stay up to date >>> [www.autolift.org/](http://www.autolift.org/)
2. Only trained and authorized personnel should position a vehicle and operate the lift. Do not allow customers or bystanders to operate the lift or be in the lift area.
3. Inspect the lift daily. Do not operate if potential problems have been identified or lift malfunctions. Do not operate if lift has damaged or broken components. Never walk or work under the lift unless all safety locks are completely engaged.
4. Never overload the lift. The rated capacity decal is located on the operator console. The hydraulic system on this lift is not designed to be a load holding device. Mechanical safety locks must be engaged before proceeding under the lift for vehicle servicing or lift maintenance. Never override operating controls. This is unsafe and will void the warranty.
5. Before driving a vehicle onto the lift, insure that both slip plates and turn plates have all lock mechanisms securely in position. Also insure that the lift and lift area is clear of all debris and that all oil and grease has been cleaned from runway surfaces.
6. Before raising or lowering the lift, always totally secure the vehicle with wheel chocks.
7. When using a jack(s) to raise a vehicle, position jack lifting pads to contact vehicle manufacturer's recommended lifting points (see CD included with the lift). Raise jack slowly until all pads contact the vehicle. Confirm that the vehicle is stable on the jack(s) before raising to desired working height.
8. Some pickup trucks may require optional truck adapters to clear running boards and other installed accessories. Special care must be exercised with pick-up trucks to insure safe lifting. Always use vehicle manufacturer's lifting points and insure the contents of the cargo box will not affect vehicle balance while on the jack(s).
9. Important: Removal or installation of heavier parts can change the vehicle's center of gravity on the jack(s) resulting in a critical load shift. The vehicle may then be unstable. Plan ahead for this possibility to insure continued safety and refer to the vehicle manufacturer's service manual for recommended procedures.
10. Always keep the lift area free of obstructions and debris. Grease and oil spills should be cleaned up immediately.
11. Never raise a vehicle on the lift with passengers inside. Before lowering, check the lift and lift area and remove all obstructions. Before removing vehicle from the lift or lift area, confirm an unobstructed exit.

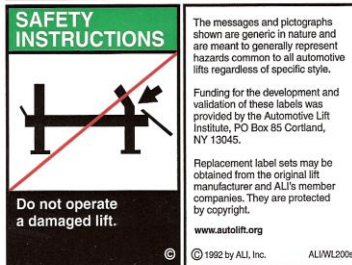
**Safety continued on page 6 .....**

# Safety Instruction and Information Decal Kit (included with the lift)

## Automotive Lift Institute, Inc.



The messages and pictographs shown are generic in nature and are meant to generally represent hazards common to all automotive lifts regardless of specific style.  
Funding for the development and validation of these labels was provided by the Automotive Lift Institute, PO Box 85 Cortland, NY 13045.  
Replacement label sets may be obtained from the original lift manufacturer and ALI's member companies. They are protected by copyright.  
www.autolift.org ©1992 by ALL Inc. ALIWL200c



The messages and pictographs shown are generic in nature and are meant to generally represent hazards common to all automotive lifts regardless of specific style.  
Funding for the development and validation of these labels was provided by the Automotive Lift Institute, PO Box 85 Cortland, NY 13045.  
Replacement label sets may be obtained from the original lift manufacturer and ALI's member companies. They are protected by copyright.  
www.autolift.org © 1992 by ALL Inc. ALIWL200c

## WL200 Series Label Kit



The messages and pictographs shown are generic in nature and are meant to generally represent hazards common to all automotive lifts regardless of specific style.  
Funding for the development and validation of these labels was provided by the Automotive Lift Institute, PO Box 85 Cortland, NY 13045.  
Replacement label sets may be obtained from the original lift manufacturer and ALI's member companies. They are protected by copyright.  
www.autolift.org ©1992 by ALL Inc. ALIWL200c

## ELECTRICAL SAFETY DECAL

**ATTENTION:**  
MOTEUR NON PROTÉGÉ--PROTECTION EXTERIEURE CONTRE LA SURCHAUFFE DOIT ÊTRE ASSURÉE CONFORMÉMENT AU CODE CE, PREMIÈRE PARTIE

COURANT ADMISSIBLE MINIMAL DE LA DÉRIVATION: 25A.

COURANT NOMINAL MAXIMAL DU FUSIBLE DE LA DÉRIVATION: 30 A.

**AVERTISSEMENT:** IL EST DANGEREUX DE TROP ARROSER LE MATÉRIEL ET LES CÂBLES ÉLECTRIQUES

SI CONNECTÉ À UN CIRCUIT PROTÉGÉ PAR DES FUSIBLES UTILISER DES FUSIBLES À UNE ACTION DIFFÉRÉE MARQUÉS "D"

NE PAS UTILISER À UN NIV EAU INFÉRIEUR À CELUI DU PLANCHER DU GARAGE OU DU SOL

**CAUTION:** RISK OF ELECTRIC SHOCK - DO NOT REMOVE COVER - NO USER SERVICEABLE PARTS INSIDE - REFER SERVICING TO QUALIFIED SERVICE PERSONNEL

**SAFETY INSTRUCTIONS:** IF ATTACHEMENTS, ACCESSORIES OR CONFIGURATION MODIFYING COMPONENTS THAT ARE LOCATED IN THE LOAD PATH, AFFECT OPERATION OF THE LIFT, AFFECT THE LIFT ELECTRICAL LISTING OR AFFECT INTENDED VEHICLE ACCOMMODATION ARE USED ON THIS LIFT AND, IF THEY ARE NOT CERTIFIED FOR USE ON THIS LIFT, THEN THE CERTIFICATION OF THIS LIFT SHALL BECOME NULL AND VOID. CONTACT THE PARTICIPANT FOR INFORMATION PERTAINING TO CERTIFIED ATTACHMENTS, ACCESSORIES OR CONFIGURATION MODIFYING COMPONENTS.

**CAUTION:**  
MOTOR NOT PROTECTED-- EXTERNAL OVERHEAT PROTECTION IN ACCORDANCE WITH CE CODE, PART 1, MUST BE PROVIDED

MINIMUM CIRCUIT AMPACITY OF CONDUCTOR IS 25 A.

MAXIMUM BRANCH CIRCUIT FUSE IS 30 A.

**WARNING:** IT IS DANGEROUS TO OVERSPRAY THE ELECTRICAL APPARATUS AND WIRING

IF CONNECTED TO A CIRCUIT PROTECTED BY FUSES USE TIME DELAY FUSE MARKED "D"

DO NOT USE BELOW GARAGE FLOOR OR GRADE LEVEL

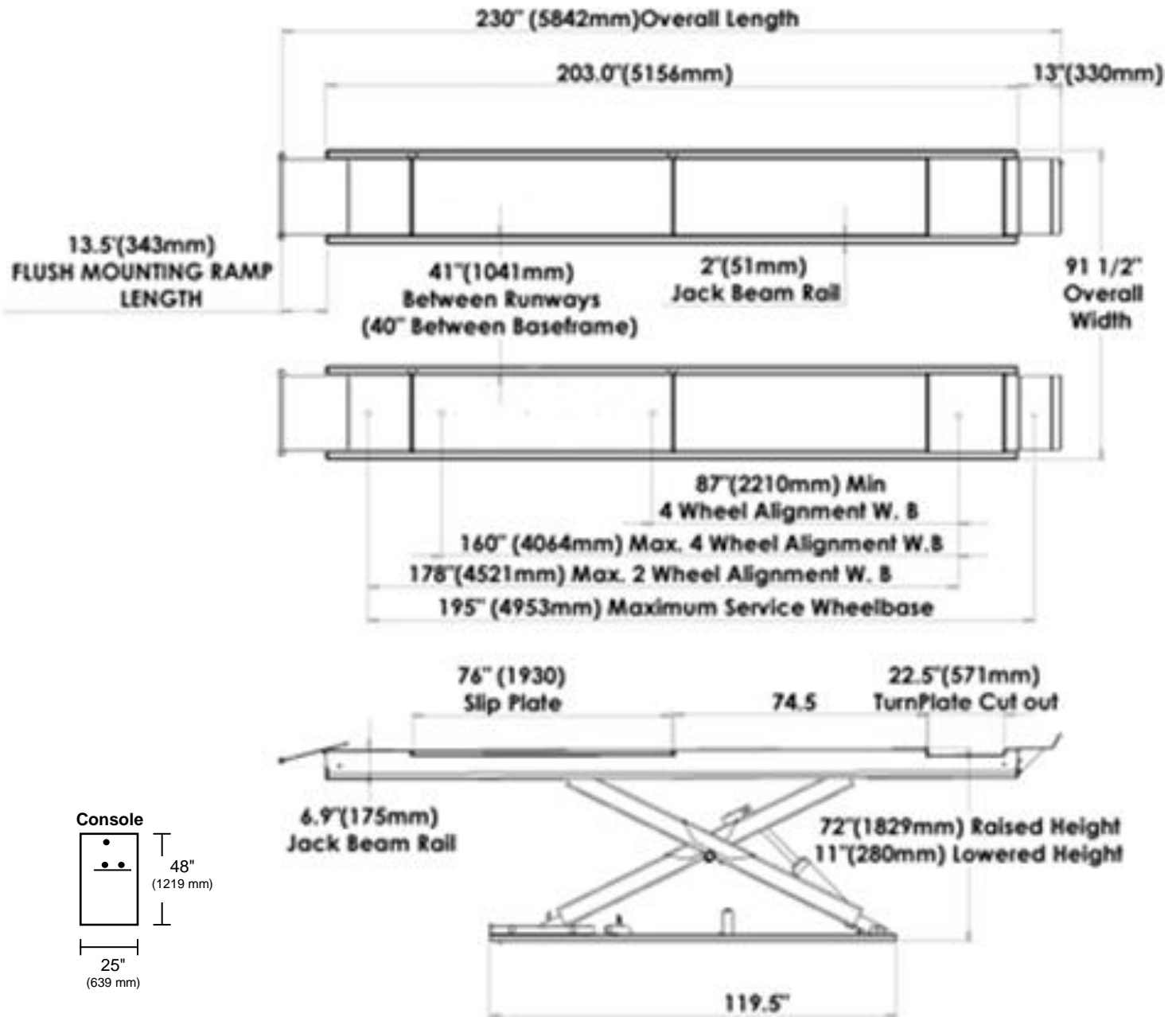
## IMPORTANT :

Insure Safety Instruction Decals and Hang Card are affixed to the lift console or operator pendant immediately following installation and before the lift is used

**Review all safety information daily with all lift operators**

**LIFT SAFETY and LIFT MAINTENANCE  
MUST BE PART OF YOUR DAILY ROUTINE**

## GENERAL REQUIREMENTS and LIFT SPECIFICATIONS



**14,000 lb. (6,350 kg) Capacity - 7,000 lbs. (3,175 kg) each Runway**

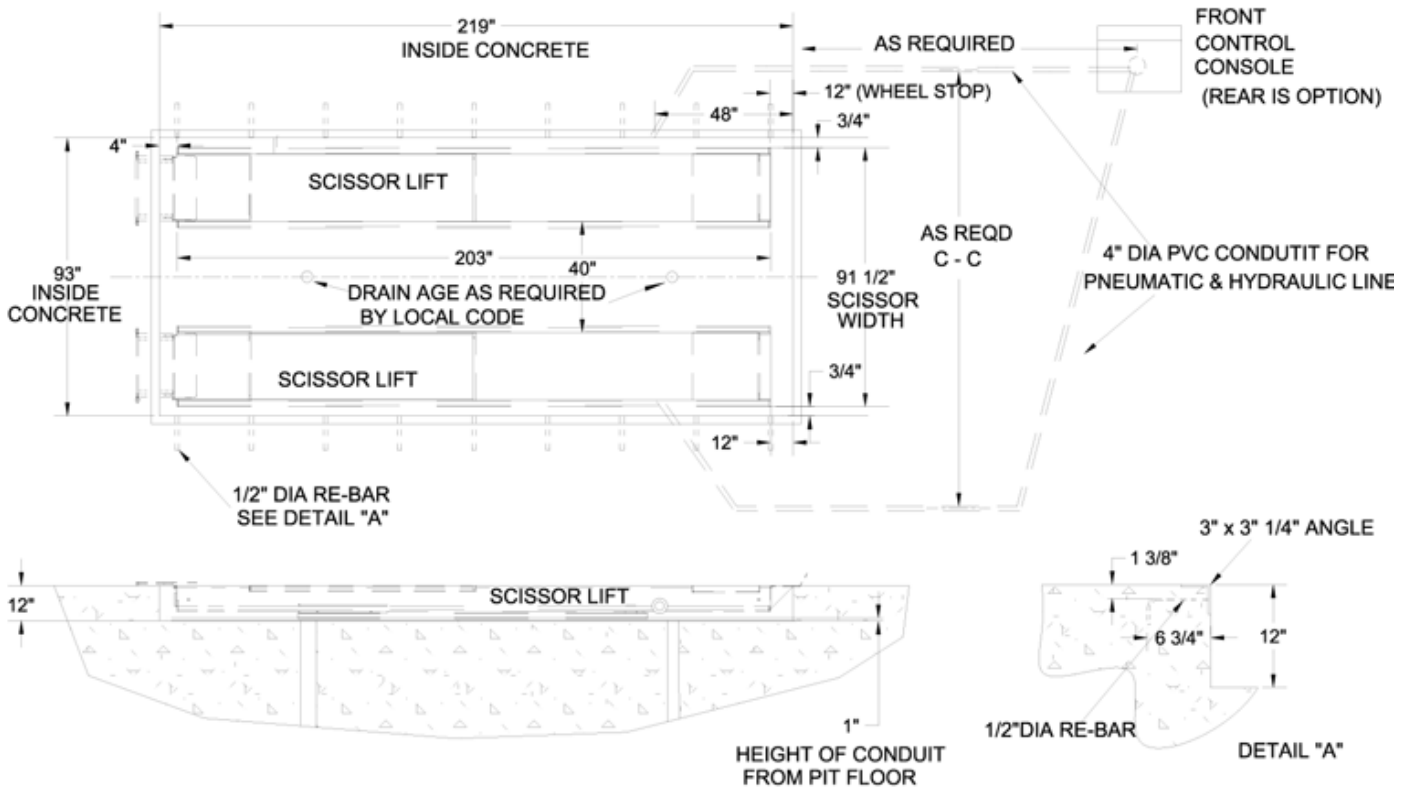
**Lift should only be installed in "pit" with a minimum of 4 inches (102mm) / 3000 psi (20.7MPa) concrete that has been aged a minimum of 30 days (see details next page)**

**A constant supply of 230 volt – 1 phase – 60 Hz – 30 amp electrical power and a constant supply of 125 psi dry compressed air is required for this lift.**

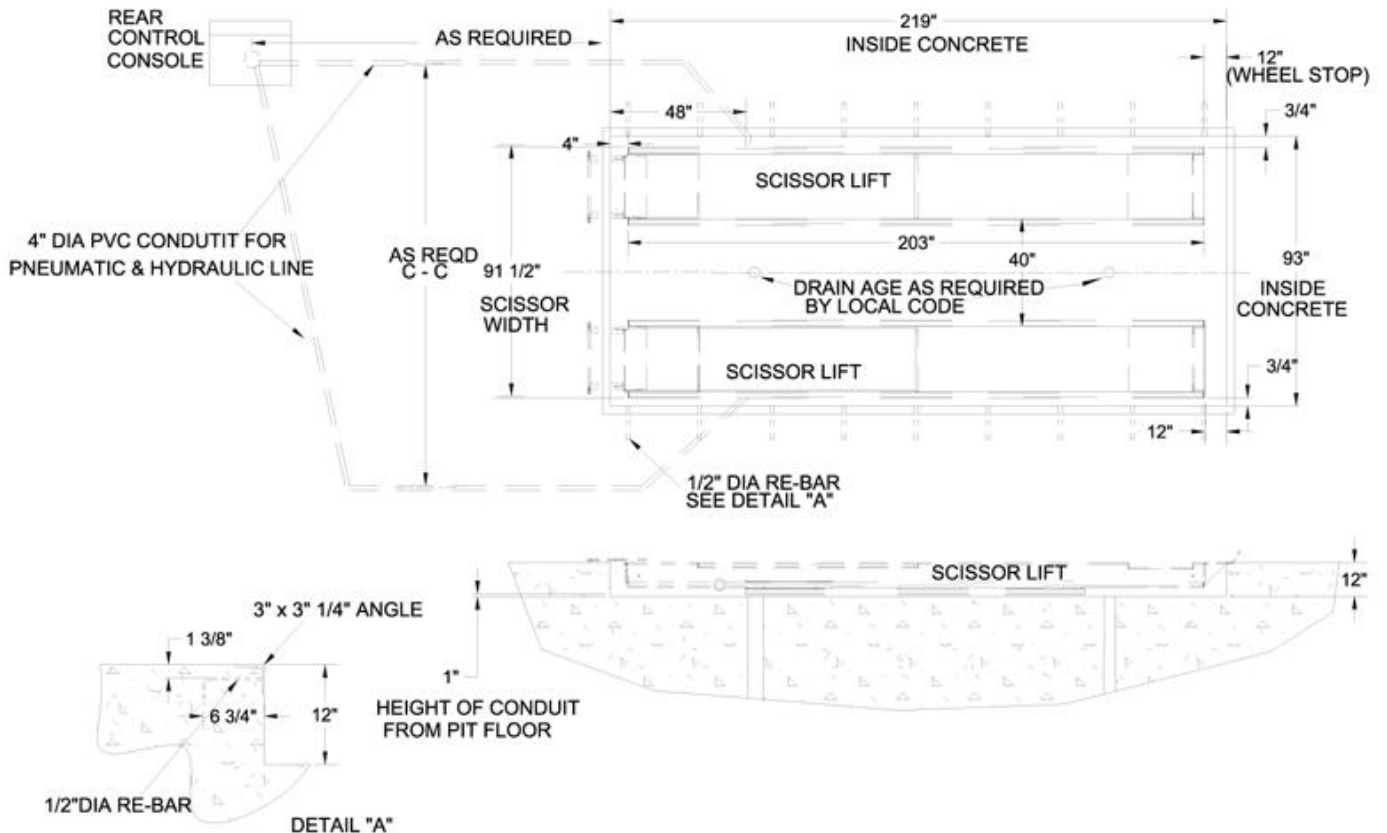
Ongoing design modifications and quality improvements may change specifications listed in this manual without notice

# In-Ground Pit Detail for Flushmount Installation

## Front Mount Console



## Rear Mount Console





# **TOOLS REQUIRED and PRE INSTALLATION PROCEDURES**

## **Tools Required:**

- ✓ 25ft. Measuring Tape
- ✓ Chalk Line and Chalk
- ✓ Side Cutters (tin snips)
- ✓ Floor Jacks – 2 (or engine crane)
- ✓ Crow Bar
- ✓ Metric and SAE Wrenches and Ratchet Sets
- ✓ Metric and SAE Allen Key Sets
- ✓ Hammer
- ✓ Screwdrivers
- ✓ 4 ft. Level (and laser level)
- ✓ Rotary Hammer Drill
- ✓ ¼ inch and ¾ inch diameter Masonry Drill Bits
- ✓ Grout – 1 pail purchased locally (see last page of this manual for reference information)
- ✓ Trowel, Float and Mixing Pail for hydraulic grout

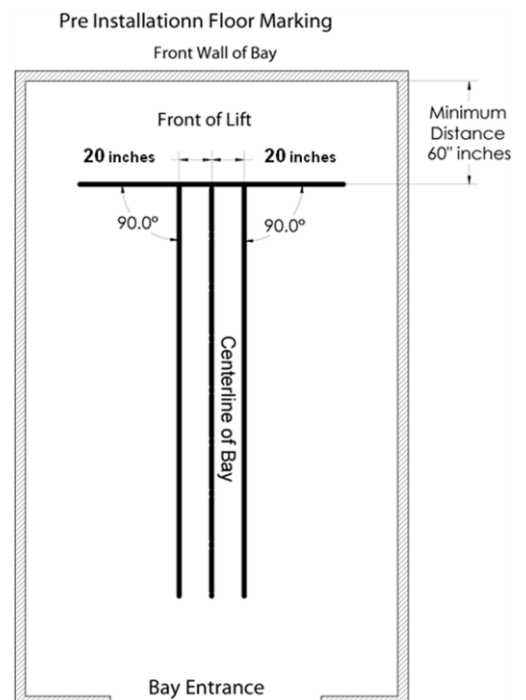
## **Pre Installation Procedures**

Before proceeding with installation, read the installation manual and insure all instructions are fully understood and all component parts are accounted for.

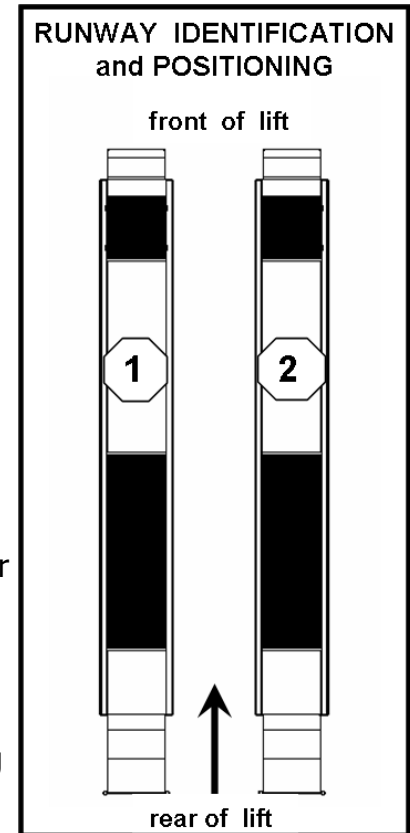
**IMPORTANT:** DO NOT CUT THE SHIPPING STRAPS HOLDING EACH RUNWAY ASSEMBLY TOGETHER UNTIL INSTRUCTED TO DO SO (step 3 – page 10).

1. Identify pit center line near the front and mark the floor. Also mark the center of pit at the rear. Connect these two points with a chalk line. Locate the position for the front of the lift and draw a second chalk line at 90° to the centerline (this will be used to position the fronts of both runway assemblies - refer to lift dimensions on pages 7 & 8).
2. At the front, measure 20 inches out from either side of the centerline and mark the floor. Near where the rear of the lift will be, measure 20 inches out from either side of the centerline and mark the floor. Using these marks draw two parallel chalk lines the length of the lift (these will be used to position the inside edge of each base frame).

**Pre Installation Instructions continued on page 10**



3. Carefully remove accessory box, (rolling air/hydraulic jack(s), and turnplate boxes if applicable) from on top of runway assemblies. Identify top runway assembly (see diagram to the right > >). Move it to its proper position on the chalk lines you have marked. Use extreme care not to damage preinstalled hydraulic, air and electrical lines stored under the rear of each runway assembly. Remove approach ramps from lower runway assembly and set off to one side. Position second runway assembly on the chalk lines you have marked. Confirm that turnplate pockets are at the front of the bay and that all base frame edges are a minimum 6 inches from any floor seam. All anchor bolts must also be a minimum of 6 inches away from any floor seam. Do not install if floor has cracks or deterioration that could affect lift stability or safety. The shop owner is responsible for confirming there are no obstructions in the installation area like floor drains, under floor piping or electrical conduit that could be damaged or would prevent safe lift installation and secure lift anchoring. Check ceiling for beams or heating ducts and walls for protruding structures, etc.. Insure that the lift can be safely installed in the position you have marked on the bay floor. Remove all packaging material from installation area.



## **INSTALLATION PROCEDURE**

See the Installation and Parts Reference section of this manual for diagrams and parts lists that will assist you during the installation process (pages 16 – 30). Use these diagrams and parts lists together with the following written instructions. Insure the lift installation complies with ANSI/ALI/ALIS, Safety Requirements for Installation and Service of Automotive Lifts.

1. Remove hydraulic, air and electrical lines from under the rear of each runway assembly. Use extreme care not to damage any of these preinstalled items. Place on top of runway.
2. Unbolt steel shipping supports and remove from installation area.
3. Confirm that the front of both runways and inside base frame edges are on the chalk lines you have marked. Also confirm that the runway assemblies are parallel to one another (inside base frame distance front and rear must be equal - diagonal base frame distances front to rear must also be equal). After confirming that the two runway assemblies are exactly where they need to be, remove the shipping straps.
4. Unpack operator console and move to desired location (reference diagram #1).
5. Carefully uncoil hydraulic, air and electrical lines and route them to the operator console insuring there are no kinks.
6. Connect hydraulic, air and electrical lines as follows: (reference diagrams #3 to #8)
  - (i) Connect hydraulic line from passenger side of lift to console manifold marked "passenger side". Connect hydraulic line from driver side of lift to console manifold marked "driver side".
  - (ii) Connect passenger side return oil line (5/32" black tubing) to "T" fitting from accessory box. Connect driver side return oil line (5/32" black tubing) to "T" fitting. Connect "T" fitting to oil reservoir cap in console using 5/32" black tubing from accessory box.

**Installation Procedure continued on page 11**

- (iii) Connect passenger side safety lock air line (5/32" blue tubing) to "T" fitting from accessory box. Connect driver side safety lock air line (5/32" blue tubing) to "T" fitting. Connect "T" fitting to air solenoid in console using 5/32" blue tubing from accessory box.
- (iv) Connect rolling air/hydraulic jacks air line from lift to console (if optional rolling jacks were purchased) **(rolling jacks must be installed with air lines connected to the lift before turning on the air)**

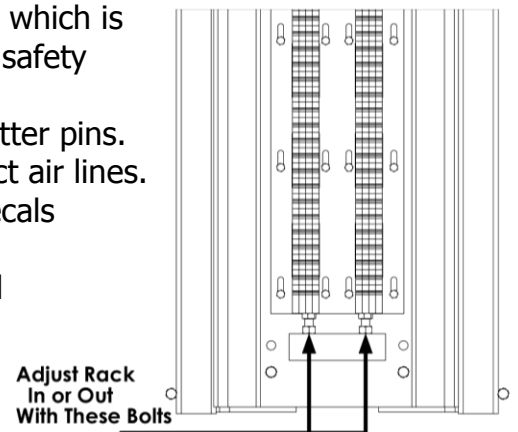
**NOTE : All electrical wiring other than low voltage (24 volts or less) should be performed by a certified electrician.**

- (v) Low Voltage Linear Transducer Connections – 1 cable from runway #1 and 1 cable from runway #2  
**Do not proceed with low voltage electrical connections at this time.** The lift must first be cycled up and down several times (step #11) to remove air pockets before connecting these cables. Low voltage electrical connection is step #16.
7. Fill oil reservoir with hydraulic oil (ISO 32).
  8. Connect operator console or control pendant to electrical service **(should be performed by a certified electrician).**
  9. Lift operation controls on the console perform the following functions:
    - "RAISE" button raises the lift. "LOWER" button lowers the lift. Note: Pressing the "lower" button will first raise the lift slightly to clear the safety locks and then proceed down to desired height.
    - "ALIGNMENT LEVEL" button lowers the lift into safety locks for alignment purposes. Note: The "alignment level" button and the "lower" button must be pressed at the same time to lower and level the lift on the safety locks.
    - "EMERGENCY STOP" button stops the lift from being raised or lowered.

**Note: Always lock both slip plates and turnplates following alignment adjustments and before removing vehicle from the lift.**
  10. Press the "UP" button and raise the lift 18 inches from the floor. Press the "DOWN" button and lower the lift down to the floor. Check hydraulic oil level in operator console reservoir and top up if required. Check all hydraulic and air lines to insure no leaks.
  11. Press the "UP" button and raise the lift 36 inches from the floor. Press the "DOWN" button and lower the lift down to the floor. Press the "UP" button and raise the lift 60 inches from the floor. Insure the safety locks under both runway assemblies are engaging properly when the lift is being raised.
  12. **Important: Before proceeding, confirm that all safety locks are totally engaged.** Dependable performance and accurate alignment results require a precisely leveled lift. Take special care to complete the following leveling process: Check both base frames with a 4 ft. level and identify the highest point. The leveling process will raise lower points on both base frames to match (or be level with) the high point you identify. Using preinstalled adjustment bolts located at the front and rear of each base frame, proceed to raise the low points on each base frame to match (or be level with) the highest point you identified. (reference diagram #9 for correct level measurement sequence)  
**Note: adjustment bolts cannot be used to support the lift when in use. They are only used during the leveling process.**  
 After the base frame has been leveled, confirm that both raised runway surfaces are also level front to back and side to side.  
 Grout thickness (measured from the floor to the bottom edge of a base frame) cannot exceed 1½ inches. Confirm this maximum limit is not exceeded by taking measurements at one foot intervals around both base frames. If you measure a distance greater than 1½ inches stop the installation and call the manufacturer at 1 - 866 - 799 - LIFT (5438).  
 The manufacturer will advise you how to proceed (grout installation is step #14).

**Installation Instructions continued on page 12**

13. If both base frames are completely level - - the bottom edges are less than 1½ inches from the floor - - and are located exactly on the chalk lines you have drawn - - drill and install all anchor bolts, washers and nuts. DO NOT TIGHTEN (anchor bolt tightening is step #18). Grout must be installed and allowed to completely cure before tightening anchor bolts. Wear safety goggles and practice caution when drilling anchor bolt holes.
14. A sufficient quantity of grout must be purchased locally. Refer to grouting instructions on the container (use last page of this manual as a reference). Evenly distribute grout under the total base frame area and finish edges with a 45 degree chamfer. Leave a small opening at the lowest point on the floor under both base frames for adequate drainage of any liquid. Refer to recommended cure times on the grout package. **Do not operate lift or disturb grout during curing process.**
15. While waiting for the grout to cure, fine tune the routing of hydraulic, return oil, air and electric lines from the lift to the console carefully placing them under line covers provided. Insure a kink free routing. Reconfirm that the operator console is exactly where you want it and that all lines are safely enclosed by the line covers. Drill and install anchor bolts, washers and nuts for line covers and operator console. Coil excess hydraulic, air and electrical lines and secure with cable ties in lower area of the operator console.
16. Connect Low Voltage Linear Transducer Cables (reference diagram #6 & #7) - one cable from runway #1 and one cable from runway #2.  
Connect the three wires in each cable as follows: both Red wires to Pin #19 - the White Wire from runway #1 to Pin #22 – the White wire from runway #2 to Pin #21 - both Black wires to Pin #20.
17. Install both front wheel stops and rear approach ramp brackets (reference diagram #10). (approach ramp installation is step #21).
18. Refer to manufacturer's recommended cure times and confirm that all grout has completely cured. Back off all leveling adjustment bolts two turns. Torque all anchor bolts to 75 ft.-lbs. (102Nm). *Anchor bolt security is a monthly maintenance check.*
19. Runways should be level (front to back and side to side) in the down position. Using the leveling support bolts located in each corner of both base frames, level both runways (reference diagram #9). This may involve raising and lowering the lift several times.
20. Adjust both safety locks to insure simultaneous and uniform engagement when lift is being raised (reference diagram to the right). This will ensure that both runways are level with one another while "on the locks" which is important for correct alignment readings. Insure these safety locks maintain their adjustment.
21. Install rear approach ramps using pins, washers and cotter pins.
22. Install rolling air/hydraulic jacks (if applicable) and connect air lines.
23. To avoid damage, safety instruction and information decals are not applied at the factory but shipped with the lift. The ALI - WL200 Series Label Kit or WL2200 hang card must be applied to lift console or control pendant before the lift is used (reference diagram #11). Insure that all lift operators are trained in all points covered by this and other safety information.



**Insure this manual along with all operation, inspection and maintenance instructions are delivered to the owner/user/employer**

## Final Checkout Procedure of Assembled Lift

- ✓ Confirm that all hydraulic and air lines are tight with no leaks
- ✓ Check hydraulic oil level in reservoir and confirm hydraulic system has been bled of all air
- ✓ Confirm that all electrical components have been wired properly and are operational
- ✓ Confirm lift base and runways are level and all anchor bolts torque to 75 ft.-lbs. (102Nm)
- ✓ Confirm safety locks are functioning properly
- ✓ Lubricate all lubrication points

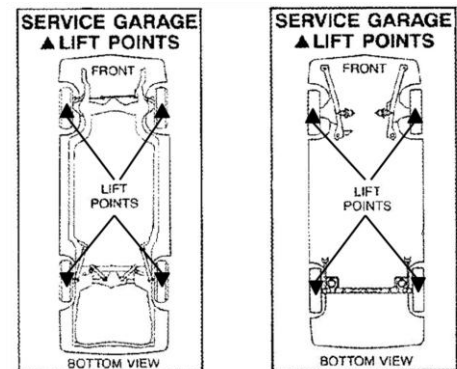
## OPERATING and MAINTENANCE INSTRUCTIONS

**LIFT OPERATION:** Before lifting a vehicle, insure all operators are qualified, have been trained and are following all safety instructions. Read and follow the ALI "Lifting It Right" manual included with the lift. (see example of SAE J2184 standard below)

**Insure that every vehicle will be securely positioned on the lift (use wheel chocks). When using air/hydraulic rolling jacks to lift a vehicle, always use vehicle manufacturer's recommended lifting points (CD included with the lift). Insure all materials stay up to date >>>**

[www.autolift.org/](http://www.autolift.org/)

**Never allow anyone under the lift when raising or lowering. Always insure mechanical safety locks are completely engaged on both sides of the lift before proceeding under the lift or a vehicle.**



Typical Label Drawings  
Reprinted with permission from SAE J2184  
©2000 Society of Automotive Engineers, Inc.

**Lift operating controls are located on the console or hand held pendant (one "up" button for raising the lift - one "level" button for lowering the lift into the safety locks for alignment - and one "down" button for lowering the lift). Note: When pressing the "down" button, the lift will first raise slightly to clear the safety locks and then proceed to lower.**

**LIFT MAINTENANCE :** Before maintaining, servicing or repairing the lift, insure that an acceptable "lock out/tag out device is activated.

The following minimum maintenance schedule must be performed by the owner and/or lift operator:

- DAILY:**
- Raise and lower the lift (with no vehicle) at the beginning of each shift to verify the runways are level and that the lift is operating properly.
  - Check all hydraulic fittings and lines for damage and leaks. Check electrical wiring for damage. Check all moving parts for uneven or excessive wear. Repair or replace all damaged, worn, or broken components immediately.
  - Clean all debris from the base frame area
  - Remove oil/grease on runways and rolling jack lift pads.

**lift maintenance continued on page 14 .....**

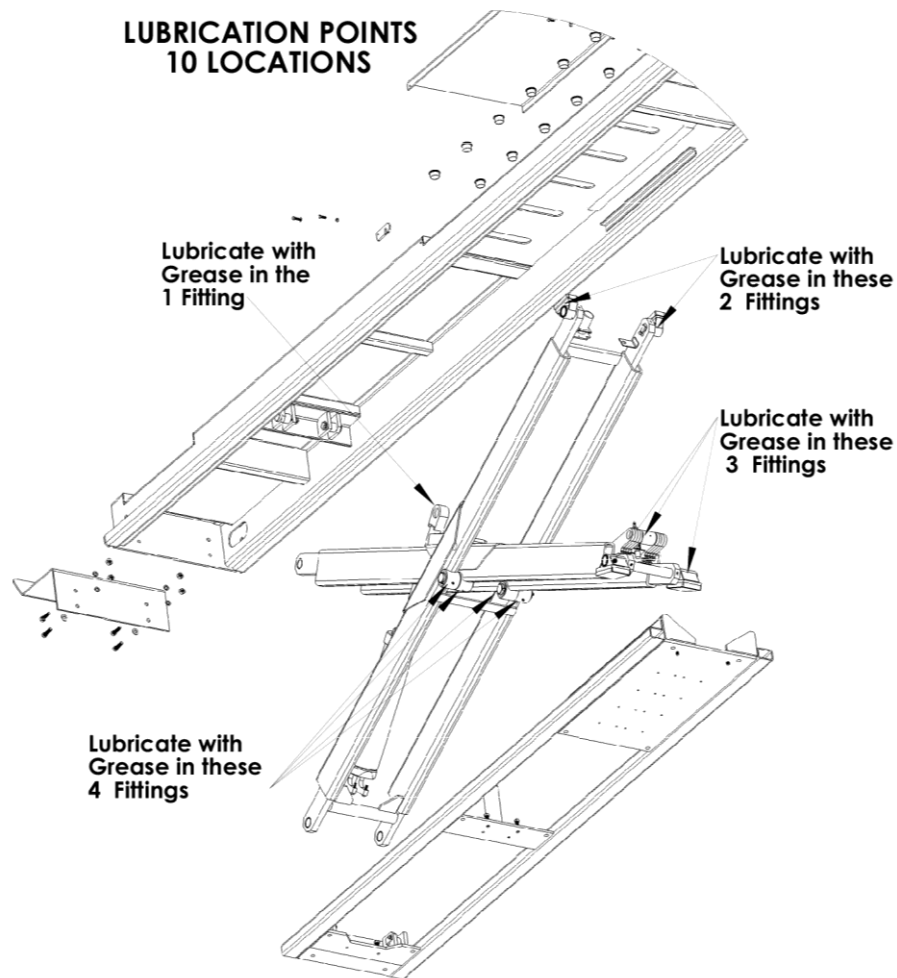
WEEKLY: - Check hydraulic fluid in console reservoir and top up if required.  
- Check safety lock adjustment.

MONTHLY: - Check that all anchor bolts are torqued to 75 ft-lbs (102Nm).  
- Clean and lubricate moving parts (see diagram #4 for grease fitting locations)

EVERY YEAR: - Arrange for a Trained Lift Service Person to inspect and certify all aspects of the lift as per "Automotive Lift Operation, Inspection and Maintenance" (ALOIM) guidelines.

EVERY TWO YEARS: - Change and replace hydraulic oil in cylinders and console reservoir.

Lubrication Specifications: - where grease is required use a multi-purpose lithium grease  
- where lubricating oil is required use a SAE 30 oil  
- where hydraulic oil is required use ISO 32 – 10W non detergent hydraulic oil.



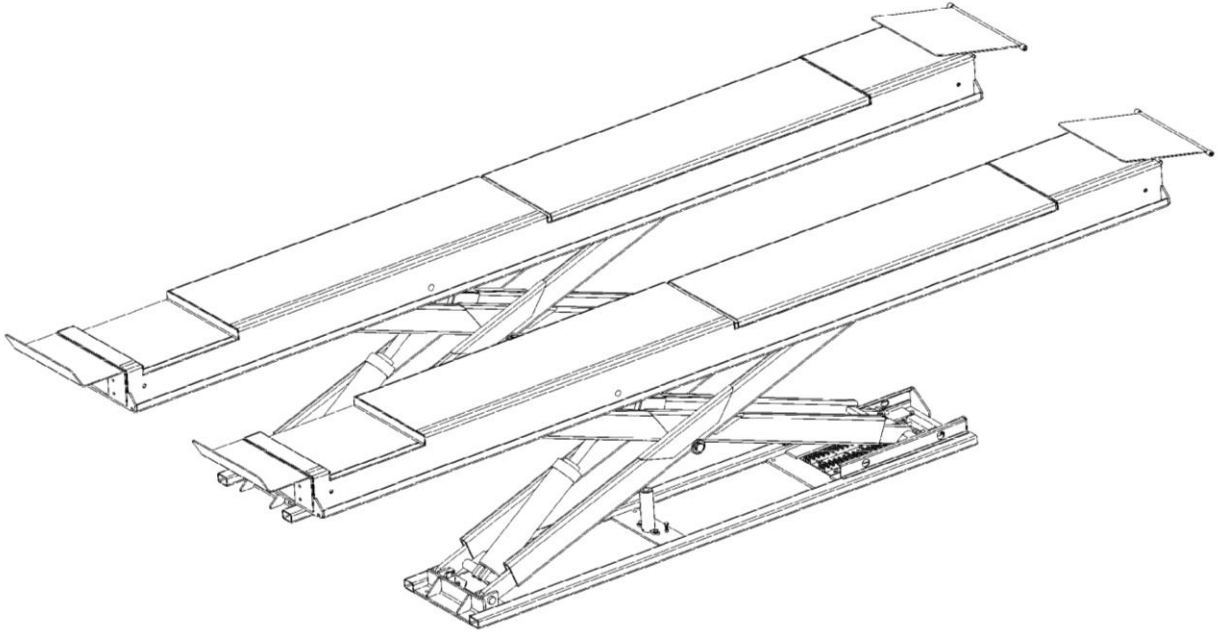
**Replace all worn or broken parts and components only with manufacturer approved/supplied parts and components**

**Replacement parts may be purchased from your local lift supplier or the manufacturer at 1 - 877 - 799 - LIFT (5438) or (905) 847 - 1198**

## **LIFT PROBLEM TROUBLESHOOTING GUIDE**

The following are suggestions to consider if you have problems with the lift. Please call a Trained Lift Service Person and/or qualified electrician for further clarification and information.

Problem	Cause	Solution
Lift Will Not Raise or Lower	<ol style="list-style-type: none"> <li>1. Blown fuse or circuit breaker</li> <li>2. "Emergency Stop" button engaged</li> <li>3. Tripped thermal overload</li> <li>4. Incorrect voltage to motor</li> <li>5. Bad wiring connections</li> <li>6. "UP" switch burned out</li> <li>7. Motor windings burned out</li> <li>8. Side to side synchronization has exceeded maximum limits</li> </ol>	<ol style="list-style-type: none"> <li>1. Replace fuse or reset/replace circuit breaker</li> <li>2. Release button or replace</li> <li>3. Reset thermal overload</li> <li>4. Supply correct voltage to motor</li> <li>5. Repair and insulate all connections</li> <li>6. Replace switch</li> <li>7. Replace motor</li> <li>8. Call a Trained Lift Service Person for assistance</li> </ol>
Lift Will Not Raise	<ol style="list-style-type: none"> <li>1. Air in oil or low oil level</li> <li>2. Lowering Valve leaks</li> <li>3. Motor runs backward</li> <li>4. Pump damaged</li> <li>5. Pump will not prime</li> <li>6. Relief Valve leaks</li> <li>7. Voltage to motor incorrect</li> <li>8. Lift overloaded</li> </ol>	<ol style="list-style-type: none"> <li>1. Check fluid level, oil seal, bleed system</li> <li>2. Clean valve or replace</li> <li>3. Check for correct wiring</li> <li>4. Repair or replace pump</li> <li>5. Check fluid level and pick-up tube - replace pump</li> <li>6. Clean Relief Valve (replace if necessary)</li> <li>7. Supply correct voltage to motor</li> <li>8. Verify that loaded vehicle weight does not exceed rated lift capacity</li> </ol>
Lift Will Not Lower	<ol style="list-style-type: none"> <li>1. Faulty lowering solenoid valve</li> <li>2. Obstruction under lift or in roller tracks</li> </ol>	<ol style="list-style-type: none"> <li>1. Replace valve</li> <li>2. Carefully remove obstruction</li> </ol>
Lift Will Not Hold Pressure	<ol style="list-style-type: none"> <li>1. Contamination in system</li> <li>2. Internal Cylinder leaks</li> <li>3. Lowering Valve leaks</li> <li>4. Check Valve leaks</li> <li>5. External leaks</li> </ol>	<ol style="list-style-type: none"> <li>1. Check oil level - bleed cylinders - remove contamination - replace oil seal</li> <li>2. Check fitting, replace cylinder</li> <li>3. Contaminated fluid, handle binds, clean valves</li> <li>4. Clean check valve (replace if necessary)</li> <li>5. Check all fittings and repair leaks</li> </ol>
Lift Going Up Out of Level	<ol style="list-style-type: none"> <li>1. Lift installed on un-level floor</li> <li>2. Linear Transducer Cables at the lift have changed position relative to one another</li> </ol>	<ol style="list-style-type: none"> <li>1. Reinstall on level surface</li> <li>2. Adjust (rotate) one cable to match the position of the opposite cable. Call a Trained Lift Service Person if problem persists</li> </ol>
Anchors Will Not Stay Tight	<ol style="list-style-type: none"> <li>1. Holes drilled oversize</li> <li>2. Concrete floor thickness or holding strength not sufficient</li> </ol>	<ol style="list-style-type: none"> <li>1. Relocate lift using the correct bit to drill holes</li> <li>2. Break out old concrete and re-pour new foundation per lift installation instruction</li> </ol>
Locking Mechanisms Do Not Engage / Disengage	<ol style="list-style-type: none"> <li>1. Safeties are binding</li> <li>2. Faulty air cylinder</li> <li>3. Damaged air line</li> <li>4. Safety locks do not latch properly</li> <li>5. Safety locks do not disengage</li> </ol>	<ol style="list-style-type: none"> <li>1. Lubricate mechanism</li> <li>2. Replace air cylinder</li> <li>3. Repair/replace air line</li> <li>4. Adjust mechanisms per lift installation instructions</li> <li>5. Check air supply and air cylinder – replace if required. Reset electronic circuit by pressing "Emergency Stop Button" for 15 seconds and then release it. Call a Trained Lift Service Person</li> </ol>



**14,000 lb. ( 6350 kg) FLUSHMOUNT SCISSOR LIFT**

**Model TLSS14ALOFRR1**

# Lift Illustrations & Parts Lists

for installation & service part reference  
SAVE this MANUAL and ALL INSTRUCTIONS

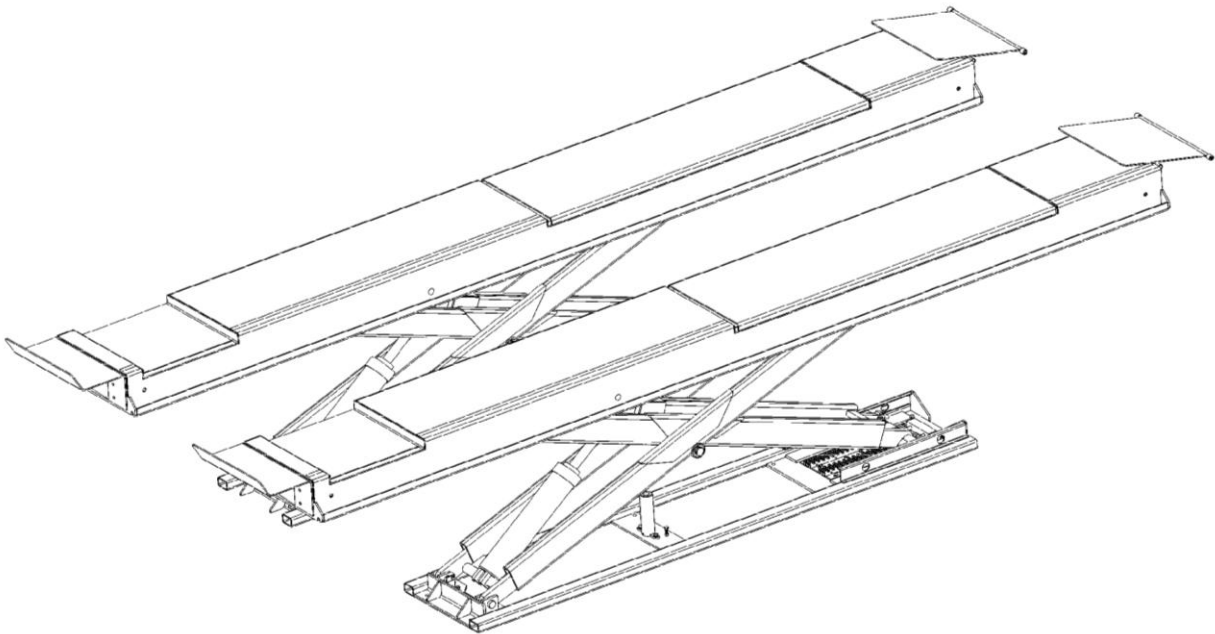
Total Automotive Lifting Solutions Inc.  
2300 Speers Rd. Oakville, Ontario L6L 2X8  
Phone: (905) 847-1198 Fax: (905) 891-1214  
www.TLSLifts.com

Part Number : D -SLSM -14FM  
Issue 0 13 Effective : December 15, 2010  
Supersedes Issue 0 12 - April 15, 2009



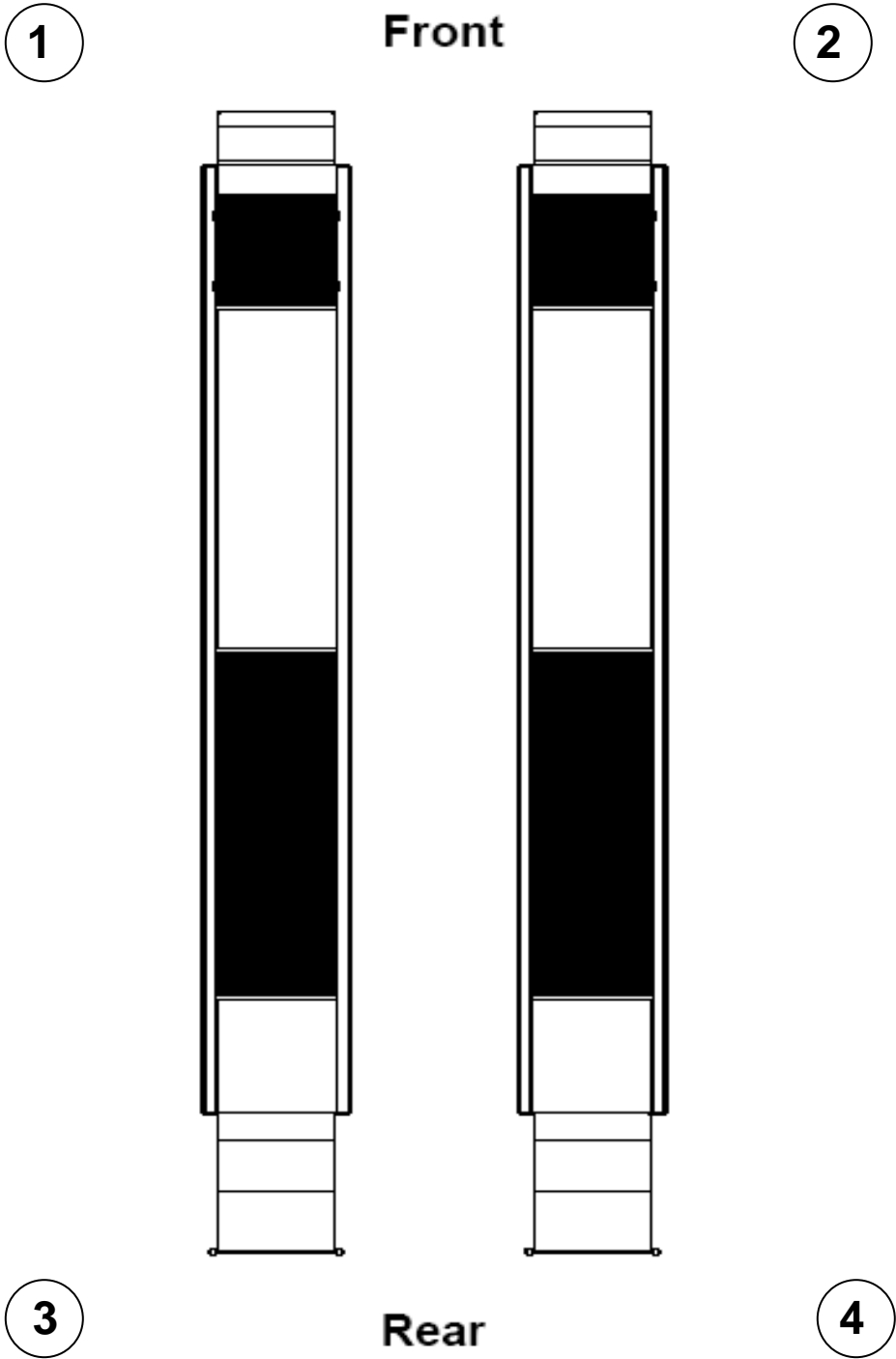
# **LIFT ILLUSTRATIONS and PARTS LISTS**

The diagram below identifies main component parts and the order in which they are to be installed. Numbers correspond to installation diagrams found in the chart below and on following pages. Page numbers for each diagram is also found in the chart below. These diagrams, along with related parts lists, will assist you when installing and servicing this lift. Please insure these lift diagrams and parts lists are kept in a secure place for quick reference.



<b><u>Diagram Number</u></b>	<b><u>Diagram Description (includes Part List)</u></b>	<b><u>Page Number</u></b>
<b>1</b>	<b>Operator Console Locations</b>	<b>18</b>
<b>2</b>	<b>Main Component Assemblies</b>	<b>19</b>
<b>3</b>	<b>Scissor Assembly and Components</b>	<b>20</b>
<b>4</b>	<b>Scissor Assembly and Hydraulics</b>	<b>21 - 22</b>
<b>5</b>	<b>Console Hydraulic Connections</b>	<b>22 - 23</b>
<b>6</b>	<b>Air System Connections</b>	<b>24</b>
<b>7</b>	<b>Top View of Low Voltage Console Connections</b>	<b>25</b>
<b>8</b>	<b>Rear View of Low Voltage Console Connections</b>	<b>27</b>
<b>9</b>	<b>Leveling Procedure</b>	<b>28</b>
<b>10</b>	<b>Wheel Stop and Rear Approach Ramp Installation</b>	<b>29</b>
<b>11</b>	<b>Safety Decal Installation</b>	<b>30</b>
<b>12</b>	<b>Information Sheet – Grout Material</b>	<b>31</b>

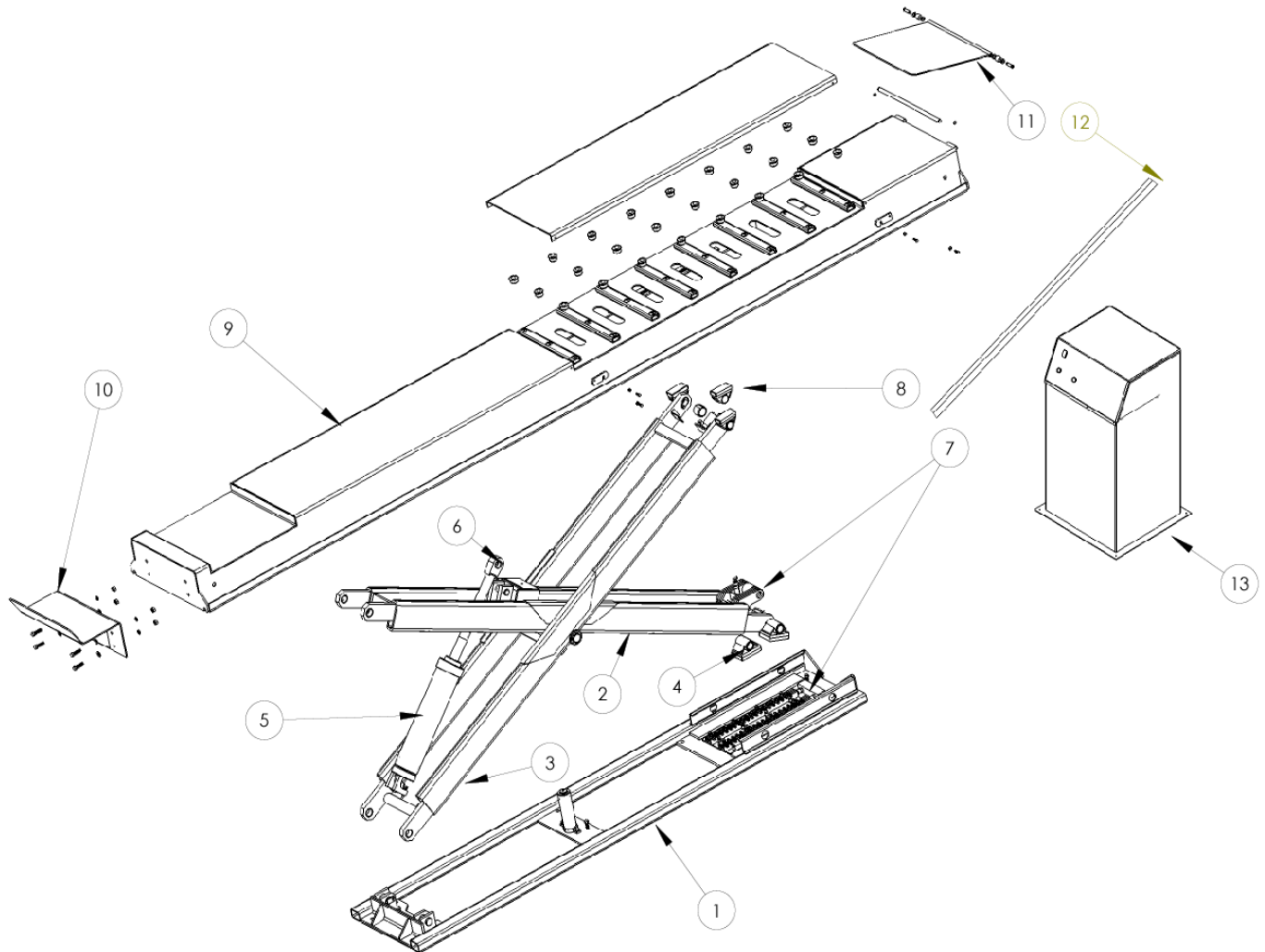
**Diagram #1 : OPERATOR CONSOLE LOCATIONS**



Refer to Pit Drawing – page 8 for additional details

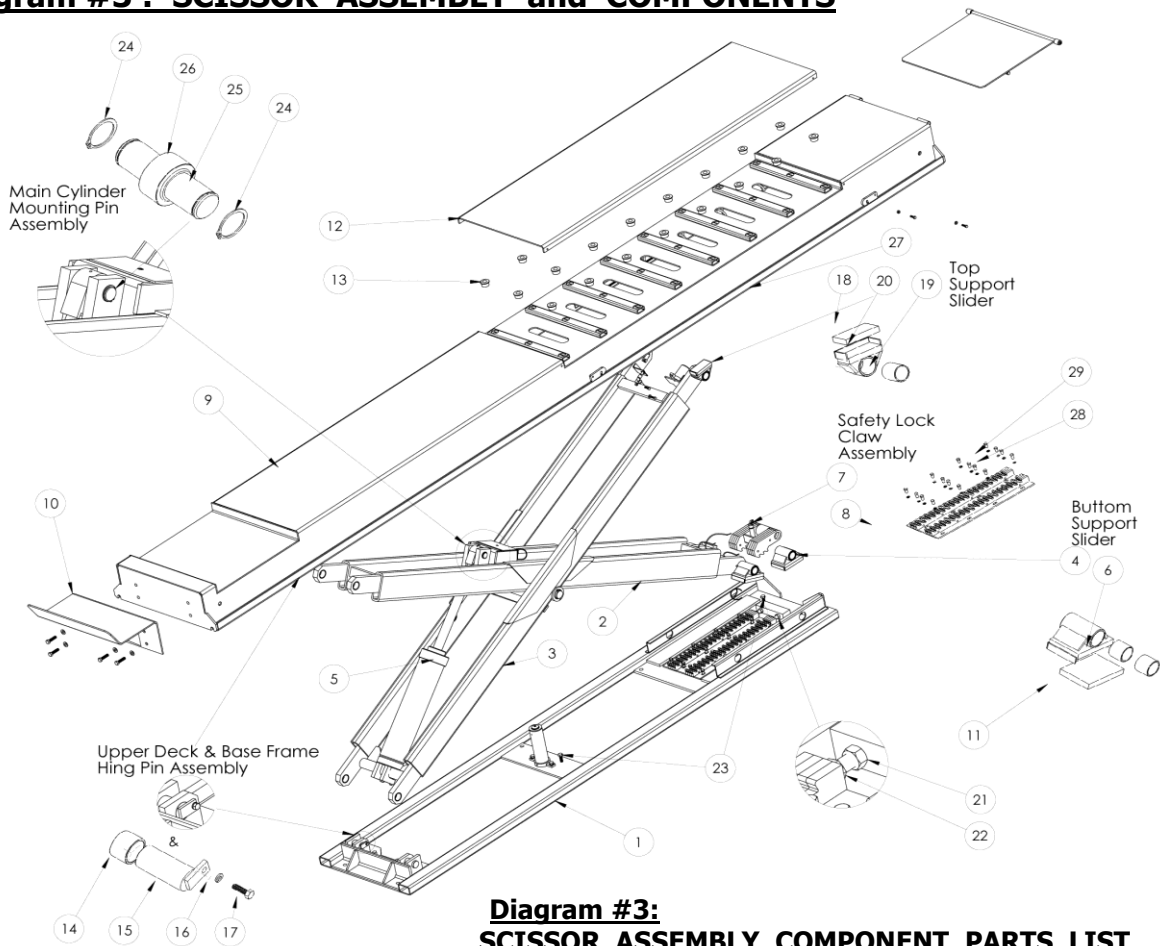
## **Diagram #2 : MAIN COMPONENT ASSEMBLIES**

### **Diagram #2 : MAIN COMPONENT ASSEMBLIES**



Item	Part Number	Description	Qty
1a	2000021D-R1	Runway #1 (driver side deck weldment – north America)	1
1b	2000021P-R1	Runway #2 (passenger side deck weldment – north America)	1
2	2000024	Wheelstop Weldment	2
3	41140029	Approach Ramp	2
4	1000008-R1	Slip Plate	2
5	2000018	Inner Scissor Arm Set	2
6	2000019	Outer Scissor Arm Set	2
7	2000023-R1	Baseframe Weldment	2
8	2000029	Safety Lock Rack Weldment	4
9	2000037	Console (housing only)	1
10	1000168	Hydraulic/Electric/Air Line Cover c/w 16 x ¼" nail-in anchors	3
11	3000036	½ - 13 x 4 ¼" Concrete Wedge Anchors	18

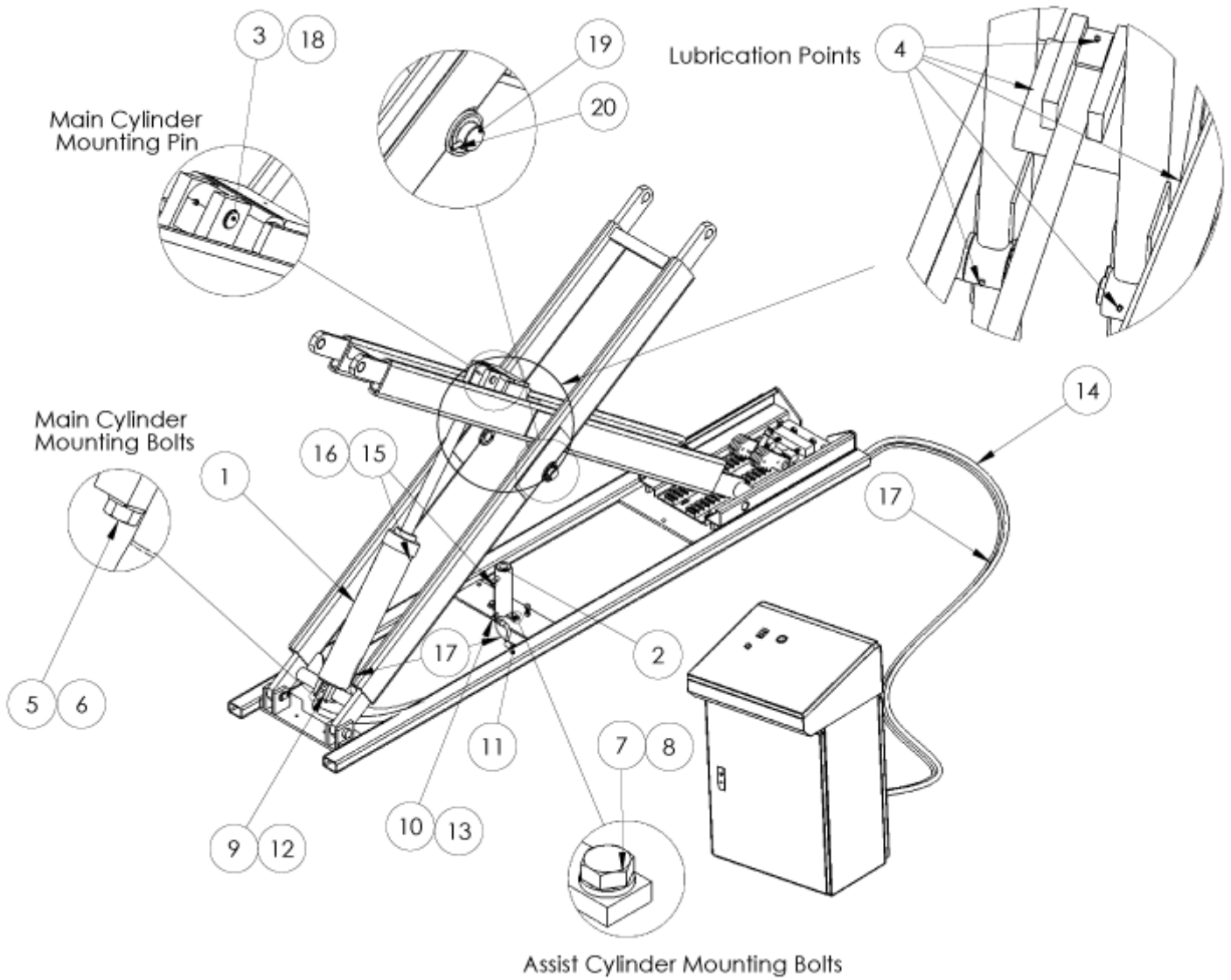
### Diagram #3 : SCISSOR ASSEMBLY and COMPONENTS



**Diagram #3:  
SCISSOR ASSEMBLY COMPONENT PARTS LIST**

Item	Part Number	Description	Qty.
1	41140007	BASE FRAME ASSEMBLY	
2	41140012	SCISSOR DRIVE ARM ASSEMBLY	2
3	41140013	SCISSOR PULL ARM ASSEMBLY	2
4	41140031	BOTTOM SUPPORT SLIDER	4
5	41140033	MAIN HYDRAULIC CYLINDER	2
6	31140052	1.75"OD x 1.5"ID.1.5"L OIL IMPREGNATED	4
7	41140021	SAFETY LOCKING CLAW SYSTEM	2
8	21140031	RACK WELDMENT W / SAFETY PLATE	2
9	41140005	DECK SUB ASSEMBLY	2
10	41140015	WHEEL STOP ASSEMBLY	2
11	11140051	BOTTOM SLIDER PLATE MAT: UHMW	4
12	11140013	SLIP-PLATE SKIN	2
13	31140005	7/8" BALL TRANSFER ( SKF)	24
14	31140051	ID 1.5" x OD 1.75" x 1 1/8"LG BRONZE BUSHING (OIL)	4
15	21140026	ROLLER 1.5 DIA PIN ASSEMBLY/ (BOTTOM & TOP)	4
16	3C140029	5/16" SPRING WASHER ( LW 0.3125)	4
17	3C140035	5/16-NC x 1 BOLT	4
18	11140052	TOP SLIDER PLATE MAT: UHMW	4
19	31140053	1.5" x 1.75" x 2"L BRONZE BUSHING (Oil Impregnated)	4
20	41140032	TOP SUPPORT SLIDER	4
21	3C140036	5/8-NC x 2 BOLT ( Base Frame Stop)	4
22	3C140059	1/2 HEX NUT GR.5	4
23	3C140040	1/2-NC x 2 BOLT ( Base Frame Leveling)	6
24	3C140049	EXT.CLIP RING FOR 1-1/4" DIA SHAFT	4
25	11140033	MAIN CYLINDER MOUNTING PIN	2
26	31140072	SPHERICAL PLAIN BEARING, #12SF 20	2
27	31140044	STRING POTENTIOMETER S/N: 38021365	2
28	3C140037	3/8-NC x 3/4" L SOC. HD. CAP SCREW	16
29	3C140030	3/8" SPRING WASHER	16

**Diagram #4 :**  
**SCISSOR ASSEMBLY and HYDRAULICS**



**Diagram #4: SCISSOR ASSEMBLY and HYDRAULICS PARTS LIST**

Item	Part Number	Description	Qty.
1	41140010	Main Cylinder	2
2	41140011	Assist Cylinder	2
3	11140033	Main Cylinder Mounting Pin	2
4	31140013	GF-641 Hydraulic Grease Fitting 1/4 - 20 UNC	10
5	3C140039	1" x 3.5 L Hex Bolt	2
6	3C140031	1/2" Spring Lock Washer	4
7	3C140034	1/2-13 x 1" Hex. Bolt	4
8	3C140031	1/2" Spring Lock Washer	4
9	31140033	3/8 S-Fitting Male x 3/8" Male Pipe Conn.	2
<b>Parts List Continued on Page 22</b>			

**Diagram #4: SCISSOR ASSEMBLY and HYDRAULICS PARTS LIST (cont'd)**

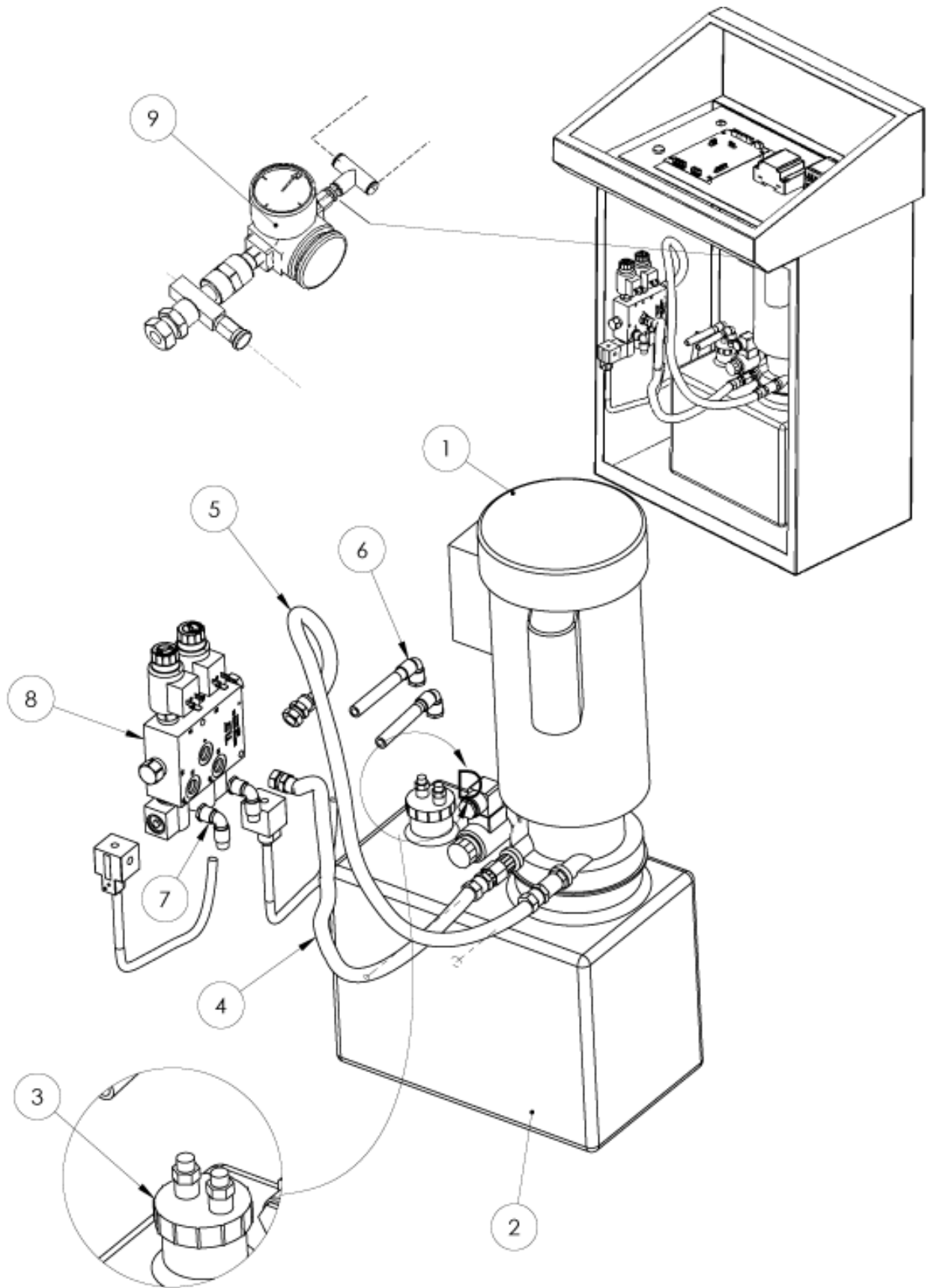
<b>Parts List Continued from Page 21</b>			
Item	Part Number	Description	Qty.
10	31140043	1/4 Male x 1/4" M NPT	2
11	31140035	3/8" x 3/8" x 3/8" Male Union Tee	2
12	31140032	3/8" x 48" Hose SAE 100R17 210BAR (3045PSI)	2
13	31140037	1/4 and 3/8 Hose 10.5"L (3045psi) SAE 100R17 210BAR	2
14	31140038	3/8 Hose 30'L 4506 SAE 100R17 210 BAR (3045 PSI)	2
15	31140019	Elbow Fitting KQ2L11-35S	4
16	31140018	1/8" Poly Tube For 1/8" Oil Return Fitting	2
17	31140017	1/8" Poly Tube For 1/8" Oil Return Fitting	2
18	3C140049	Ext. Clip Ring For 1-1/4" DIA. Shaft	4
19	11140034	Center Hinge Pin	4
20	31140012	1/4" DIA. x 2-1/2" L Spring Pin (slotted) SPS 0.25x2.5	4

**Diagram #5 : CONSOLE HYDRAULIC PARTS LIST**

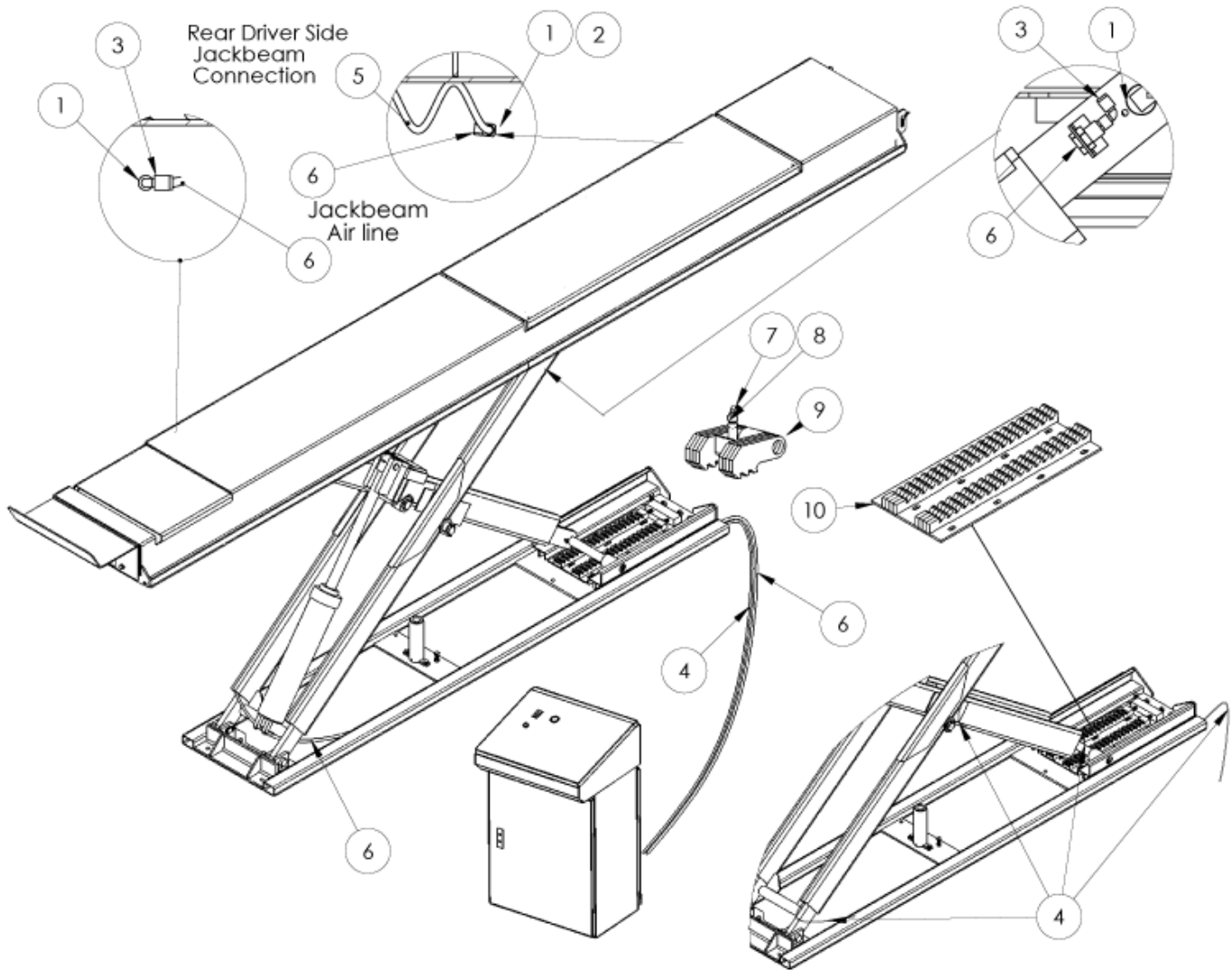
**(see diagram page 23)**

Item	Part Number	Description	Qty.
1	61140021	HYDRAULIC DRIVE MOTOR ,3HP	1
2	61140022	HYDRAULIC TANK	1
3	61140022	CAP COME WITH HYDRAULIC TANK	1
4	31140045	3/8 HYDRAULIC HOSE 15" LENGTH 4506 SAE 100R17 210BAR	1
5	31140046	1/4" HYDRAULIC HOSE 15" L761-4-REEL 738-44 FITTING	1
6	31140047	5/32 POLYURETHANE TUBING WITH FITTINGS	2
7	61140004	90 ELBOW ADAPTER SAE 070220 2503-6-6	2
8	61140001	MANIFOLD (FLOW DIVIDER-COMBINER) 2007F03-05455-01	1
9	31140110	AIR REGULATOR C/W GAUGE	1

**Diagram #5 :**  
**CONSOLE HYDRAULIC CONNECTIONS**



**Diagram #6 : AIR SYSTEM CONNECTIONS and COMPONENTS**

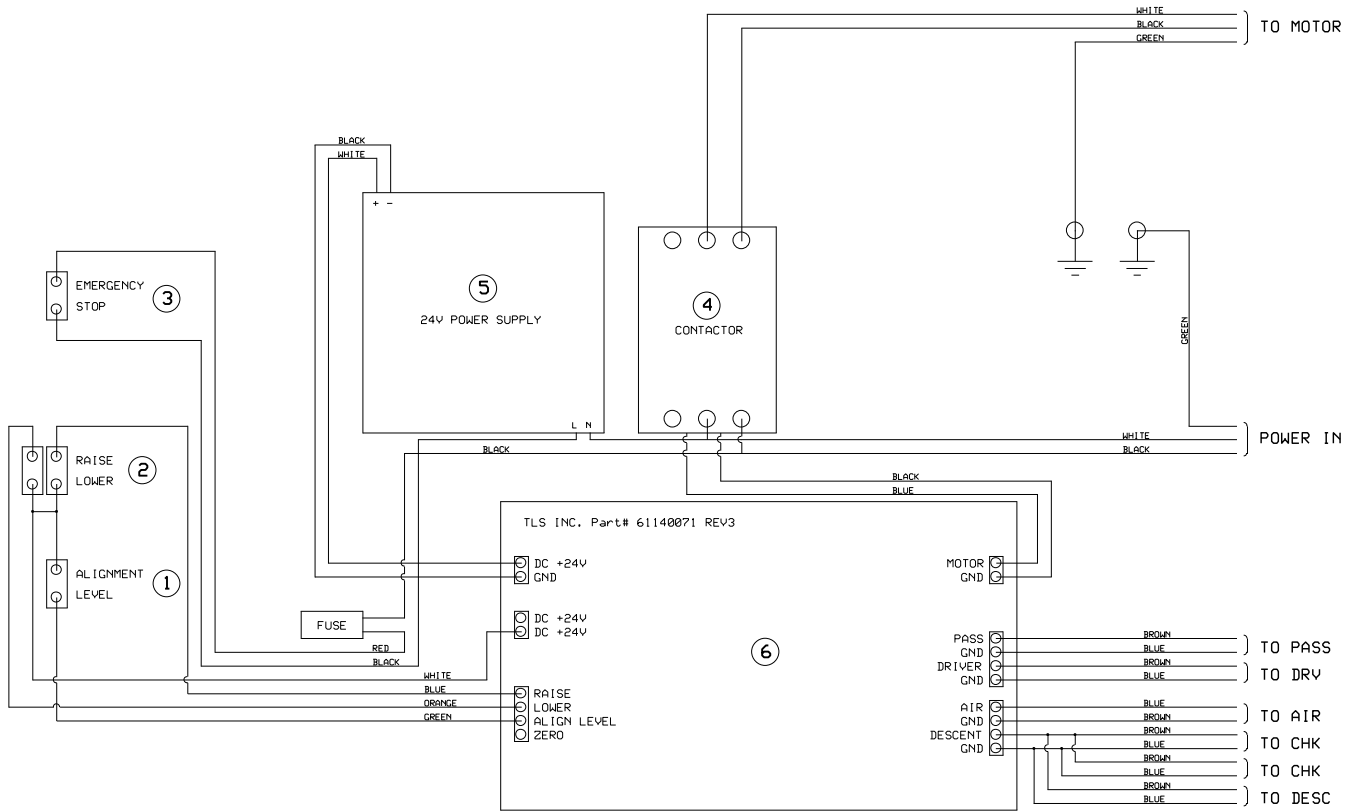


**Diagram #6 : AIR SYSTEM COMPONENT PARTS LIST**

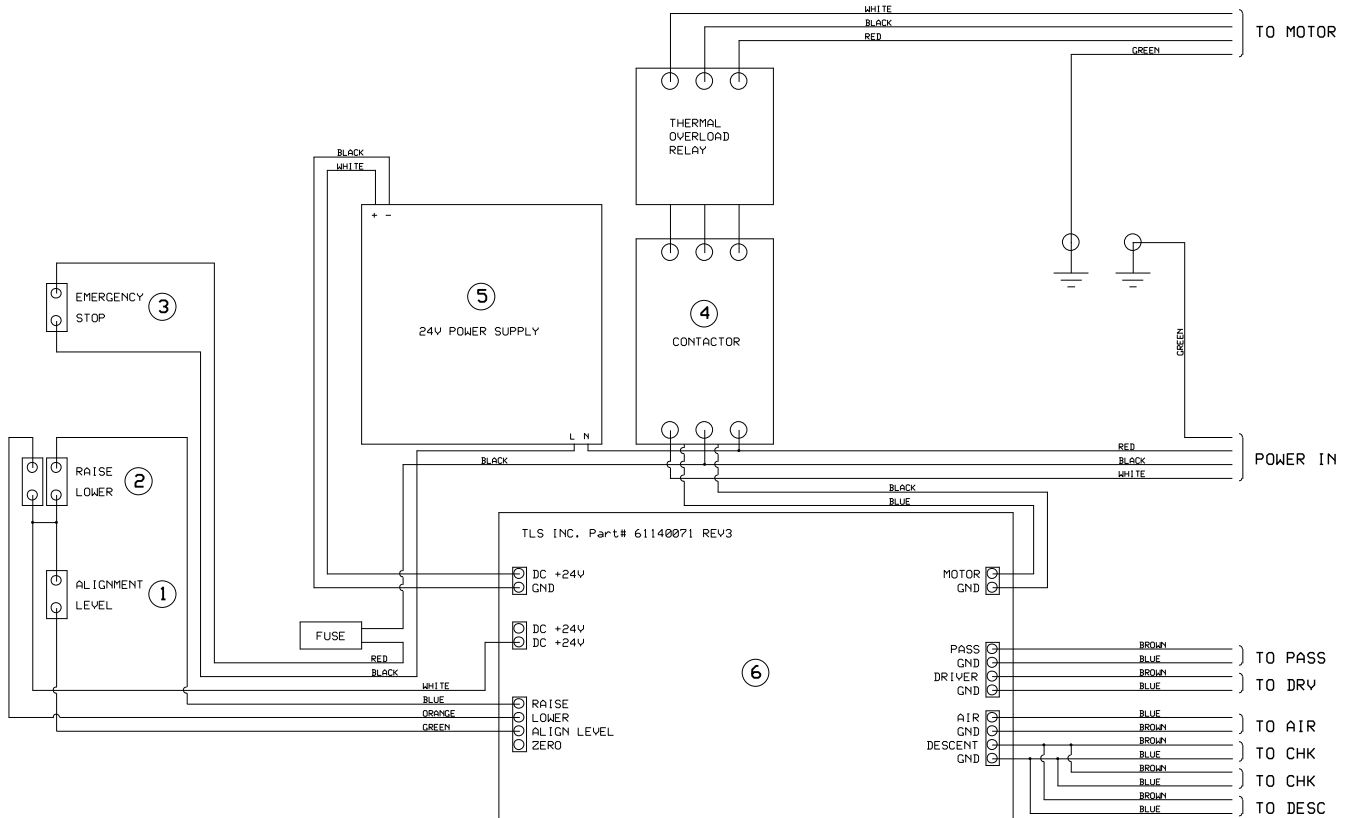
Item	Part Number	Description	Qty
1	31140024	Air CP1 Terminal Bolt 14958-S 1/4, 1/4 31/32L	2
2	31140030	Air Nut Cap / Flat Washer	1
3	31140023	3/8 Elbow Fitting KQ2L11-35S	2
4	31140018	5/32" Poly Tube	2
5	31140021	Air Hose EA-F1935-4-25 Assembly-Red (1/4X 25')	3
6	31140028	Air Hose 6 3/8 x 193"L Black Polyethylene Tubing PE064-500K	2
7	31140019	5/32 x 1/8" Elbow Fitting KQ2L11-35S	2
8	31140054	SMC Air Cylinder 4" Stork NCM B075-0100	2
9	41140021	Safety Locking Claw System	2
10	21140031	Rack Weldment W / Safety Plate	2



**Diagram #7a: LOW VOLTAGE CONSOLE CONNECTIONS TOP VIEW (1 PHASE)**



**Diagram #7b: LOW VOLTAGE CONSOLE CONNECTIONS TOP VIEW (3 PHASE)**



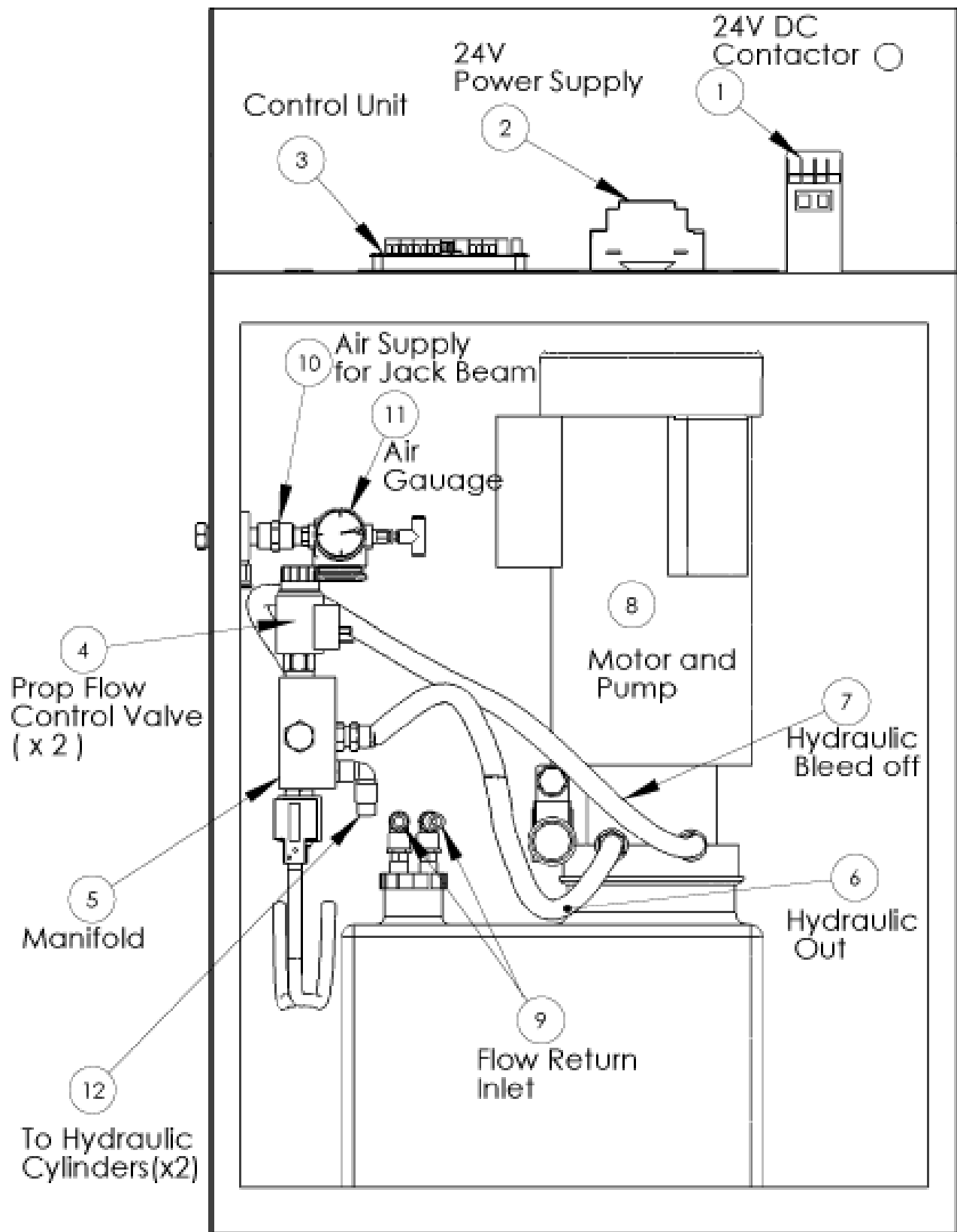
**Diagram #7 : LOW VOLTAGE CONSOLE COMPONENT PARTS LIST**

Item	Part Number	Description	Qty
1	61140075	ALIGNMENT LEVEL BUTTON	1
2	61140073	SWITCH (UP/DOWN)	1
3	61140074	RED EMERGENCY STOP PUSH/PULL BUTTON	1
4	61140076	24VDC CGC - 32D CONTACTOR UNIT	1
5	61140072	POWER SUPPLY,24V	1
6	61140071	SCISSOR LIFT CONTROLLER UNIT	1

**Diagram #8 : CONSOLE COMPONENT PARTS LIST**

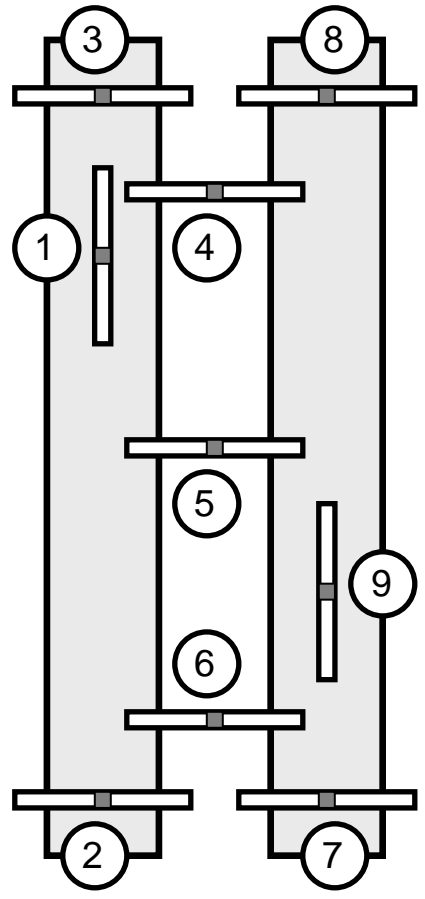
Item	Part Number	Description	Qty
1	61140076	CONTACTOR UNIT CGC - 32D-24VDC	1
2	61140072	POWER SUPPLY,24V	1
3	61140071	SCISSOR LIFT CONTROLLER UNIT	1
4	61140002	24VDC PROPORTIONAL FLOW CONTROL VALVE 0.75GPM	2
5	61140001	MANIFOLD FLOW DIVIDER-COMBINER	1
6	31140045	3/8" HYDRAULIC HOSE 15" LENGTH (Link PUMP and MANIFOLD)	1
7	31140046	1/4" HYDRAULIC HOSE 15" LENGTH (Link PUMP and MANIFOLD)	1
8	61140021	HYDRAULIC DRIVE MOTOR ,3HP (LEESON)	1
9	31140047	FLOW RETURN INLET: 5/32 POLYURETHANE TUBING WITH FITTINGS	2
10	31140024	AIR SUPPLY FOR JACK BEAM 1/4" x 1"LG NPT BULKHEAD	1
11	31140110	AIR REGULATOR C/W GAUGE	1
12	61140004	90 ELBOW ADAPTER SAE 070220 2503-6-6	2

**Diagram #8 : CONSOLE COMPONENTS and CONNECTIONS**

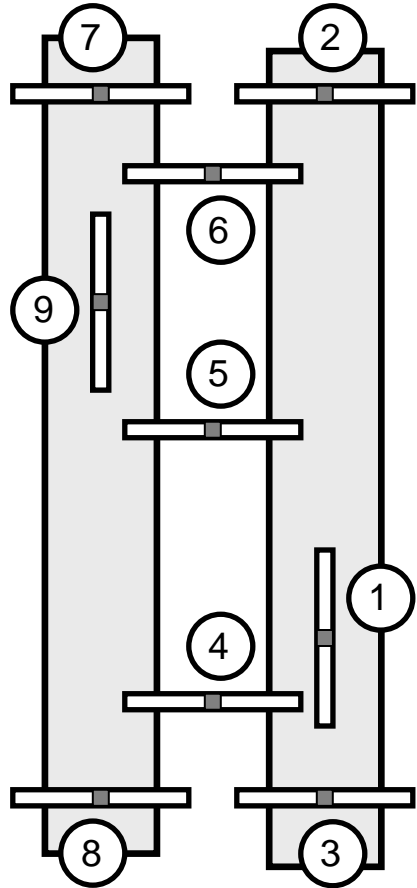


**Diagram #9 : LEVELING PROCEDURE**

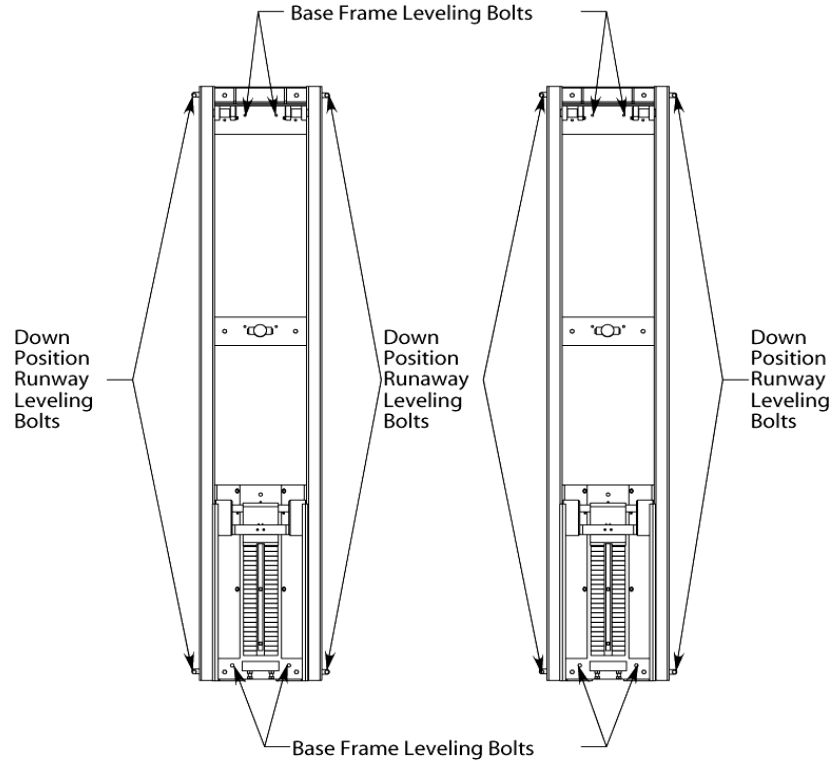
**Example #1**  
leveling start point if highest point on both base frames is here →

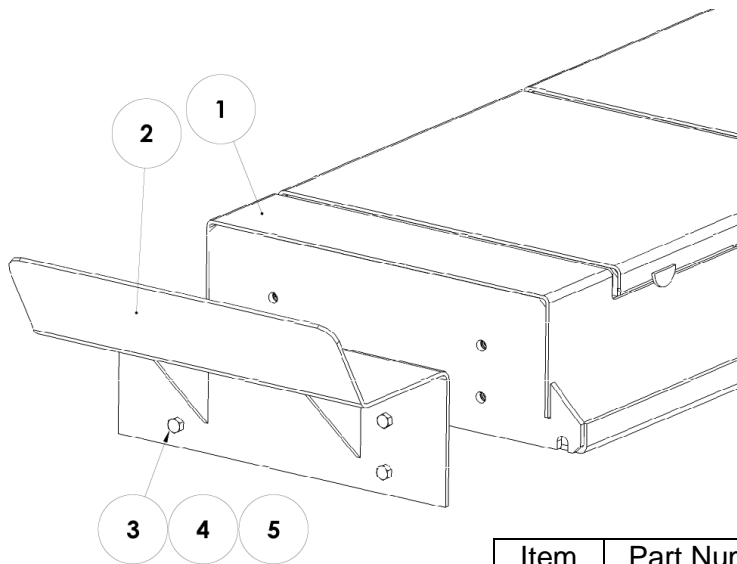


**Example #2**  
leveling start point if highest point on both base frames is here ←



**Base Frame and Down Position Runway Leveling**



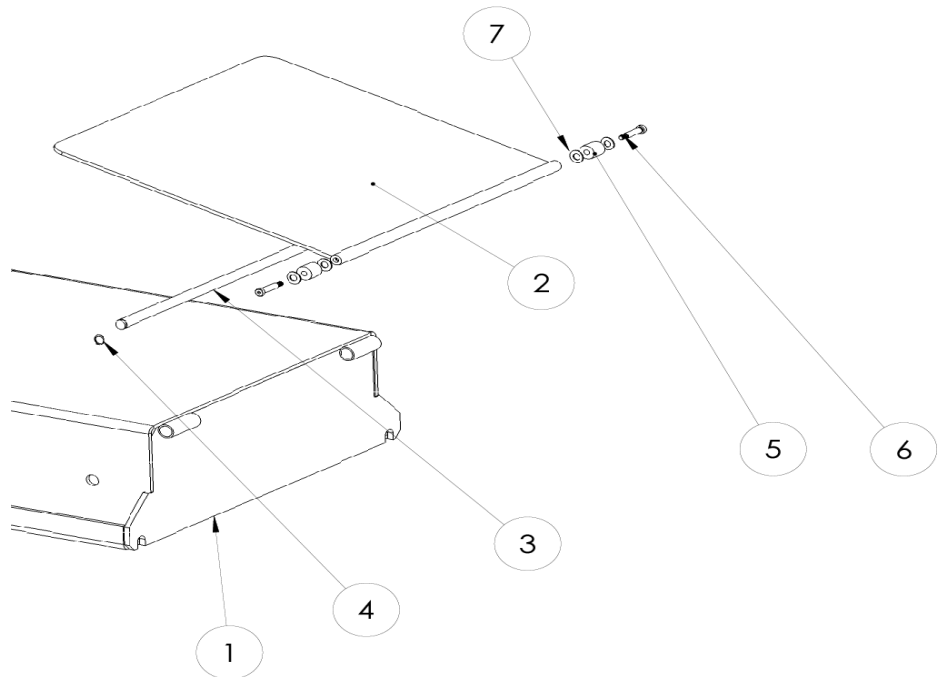


**Diagram #10 :**  
**WHEEL STOP and**  
**REAR APPROACH RAMP**  
**INSTALLATION**

**PARTS LIST:**  
**Front Wheel Stops**

Item	Part Number	Description	Qty
1	41140005	Scissor Lift Deck	2
2	41140015	Front Wheel Stop	2
3	3C140040	1/2"-NC x 2 Hex Bolt	8
4	3C140031	1/2" Spring Lock Washer	8
5	3C140059	1/2" Hex Nut Grade 5	8

**PARTS LIST:**  
**Rear Approach Ramps**



Item	Part Number	Description	Qty.
1	41140005	Scissor Lift Deck	2
2	11140119	Flush Mount Ramp Deck Skin 20" X 20" X 1/4"	2
3	11140128	Pivoting Pin for Approach Ramp	2
4	3C140047	Ext. Clip Ring for 5/8" Diameter Shaft	4
5	11140130	Ramp Roller (flush mount model)	4
6	3C140044	3/8" x 1 1/2" S.H.S.B	4
7	3C140027	7/16" SAE Flat Washer	4

# Diagram #11 : SAFETY DECAL APPLICATION

Automotive Lift Institute, Inc.



The messages and pictographs shown are generic in nature and are meant to generally represent hazards common to all automotive lifts regardless of specific style.  
Funding for the development and validation of these labels was provided by the Automotive Lift Institute, PO Box 85 Cortland, NY 13045.  
Replacement label sets may be obtained from the original lift manufacturer and ALI's member companies. They are protected by copyright.  
www.autolift.org ©1992 by ALI, Inc. ALIWL200s



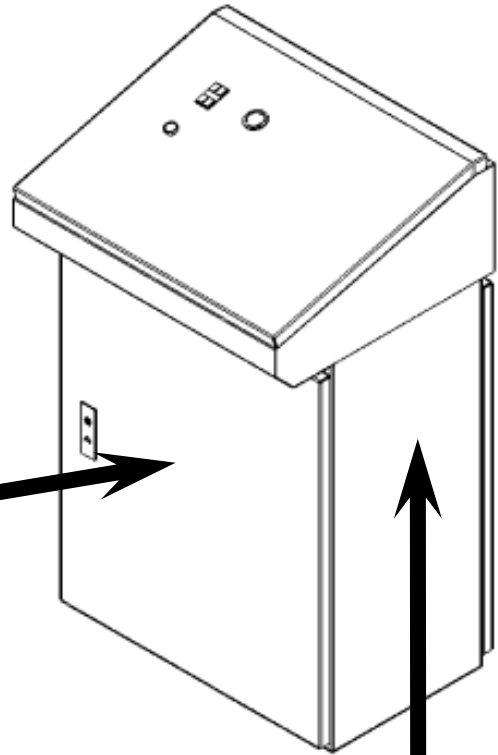
The messages and pictographs shown are generic in nature and are meant to generally represent hazards common to all automotive lifts regardless of specific style.  
Funding for the development and validation of these labels was provided by the Automotive Lift Institute, PO Box 85 Cortland, NY 13045.  
Replacement label sets may be obtained from the original lift manufacturer and ALI's member companies. They are protected by copyright.  
www.autolift.org ©1992 by ALI, Inc. ALIWL200s



WL200 Series Label Kit



The messages and pictographs shown are generic in nature and are meant to generally represent hazards common to all automotive lifts regardless of specific style.  
Funding for the development and validation of these labels was provided by the Automotive Lift Institute, PO Box 85 Cortland, NY 13045.  
Replacement label sets may be obtained from the original lift manufacturer and ALI's member companies. They are protected by copyright.  
www.autolift.org ©1992 by ALI, Inc. ALIWL200w

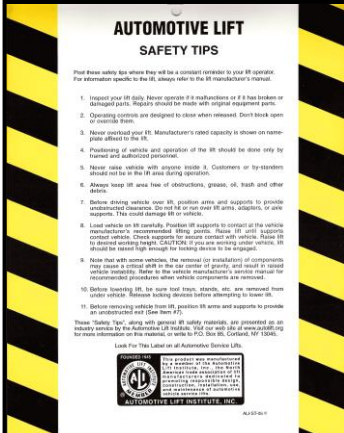


## TYPICAL PLACARD LOCATIONS



## SAFETY WARNING LABELS FOR WHEEL ENGAGING SURFACE LIFTS

- Lift Owner/User Responsibilities:
- A. This Safety Warning placard **SHALL** be displayed in a conspicuous location in the lift area.
  - B. Use one of the mounting arrangements illustrated on back of this placard.
  - C. These Safety Warning labels supplement other documents supplied with the lift.
  - D. Be certain all lift operators read and understand these labels, operating instructions and other safety related information supplied with the lift.



# LIFT SAFETY and LIFT MAINTENANCE MUST BE PART OF YOUR DAILY ROUTINE



# INSTAROK CEMENT

*All Purpose  
Anchoring Compound*

## 1. Product Description

**a. Basic Use:** Instarok Cement is a dry cement powder which when mixed with water hardens rapidly to a permanent, solid mass that is not affected by moisture, rain or submersion in water. With nearly three times the strength of concrete, Instarok Cement anchors, patches and repairs in one hour or less.

**b. Features/Benefits:**

- Can be poured or troweled.
- Expands slightly as it sets - locks permanently.
- Safe to use without danger of burns or other injury to workers.
- Free from iron - no rust staining.
- Immune to oil, grease and solvents.
- Dries to a light gray color.
- Good for interior or exterior uses.
- No added calcium chloride or corrosive agents.

**c. Typical Applications:** Railings, posts, bolts, poles, parking meters, light machine anchors, cracks, holes, pointing masonry and pipe sleeves.

**d. Limitations:** Do not use Instarok Cement below 40°F (4°C). (Note: When durability is needed for exterior patching, use Thinpave, Thickpave or Speedpave.)

**e. Composition:** Instarok Cement is an expansive hydraulic cement system along with proprietary chemical ingredients.

**f. Color/Appearance:** Similar to concrete.

## 2. Packaging

Instarok Cement is packaged in 10-lb. (4.5 Kg) tubs, 25-lb. (11.3 Kg) pails, 50-lb. (22.7 Kg) pails, and 125-lb. (56.7 Kg) drums.

## 3. Estimating/Yield

Size of Container	Yield
10-lb. (4.5 Kg)	0.10 cu. ft. (0.003 cu. m)
25-lb. (11.3 Kg)	0.25 cu. ft. (0.007 cu. m)
50-lb. (22.7 Kg)	0.50 cu. ft. (0.014 cu. m)
125-lb. drum (56.7 Kg)	1.25 cu. ft. (0.035 cu. m)

## 4. Technical Data

**a. Compressive Strength:** ASTM C 109, 2 in. (50 mm) cubes at 72°F (22°C).

Age	Strength
1 hour	2,000 psi (14 MPa)
1 day	5,000 psi (34 MPa)
3 days	5,500 psi (38 MPa)
7 days	6,000 psi (41 MPa)
28 days	7,000 psi (48 MPa)

**b. Set Times:** ASTM C 191

Initial Set: 30 minutes.

Final Set: 40 minutes.

**c. Tensile Test:** 1/2 in. (12.7 mm) diameter bolt at 1 hour: bolt fracture.

**d. Expansion:** ASTM C 157; +0.10% at 90 minutes.

## 5. Directions for Use

**a. Preparation:** Contact surfaces of concrete or masonry must be clean, sound and textured. Chip or chisel to get to sound concrete. Bolts, anchors, or rails should be clean and free of oil or grease. Blow off any dirt or dust from contact areas with compressed air.

**b. Bonding:** No bonding agent is required. Pre-dampen contact surfaces before Instarok Cement installation.

**c. Mixing:** Mix only as much Instarok Cement as is needed for the job or that can be placed in 15 minutes. Use approximately 3 pints (1.4 liter) of water for each 10 lbs. (4.5 Kg) of Instarok Cement. Mix to a smooth, pourable consistency by hand.

**d. Placing:** Pour Instarok Cement into bolt hole, rail blockout, or annular space around pole.

**e. Curing:** Cover with wet burlap or wet rags for one hour. Cure with one coat of Seal N Kure or Metcure.

**f. Maintenance:** No maintenance is normally needed. Instarok Cement may be sealed or coated with standard concrete products.

## 6. Availability

Instarok Cement is normally available immediately from your local distributor.

**Metalcrete Industries**

10330 Brecksville Road • Cleveland, Ohio 44141  
440-526-5600 • 800-526-5602 • FAX 440-526-5601

**The above information will assist you with purchasing grout material from a local source. The grout material you purchase should meet or exceed these specifications.**