

8 7 6 5 4 3 2 1

D

C

B

A

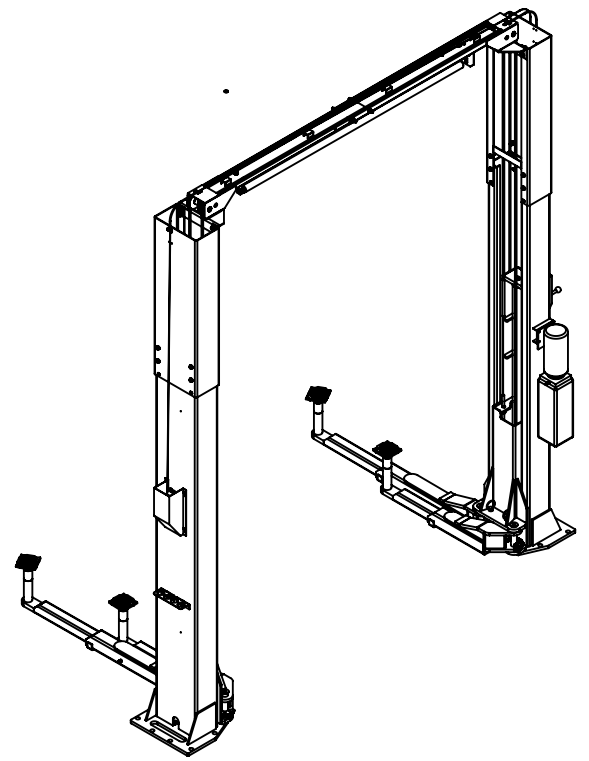
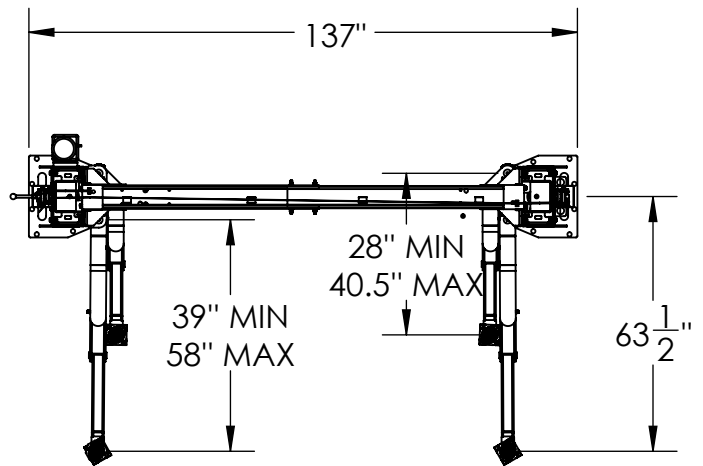

D

C

B

A

75" RAISED  
4.5" LOWERED  
W/ STANDARD PADS

84" RAISED  
13.5" LOWERED  
W/ 3" AND 6" EXTENSIONS

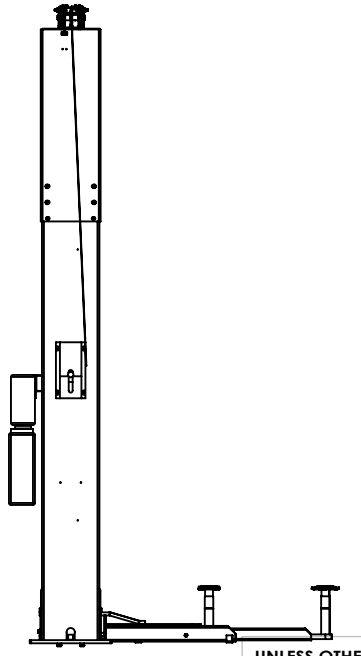
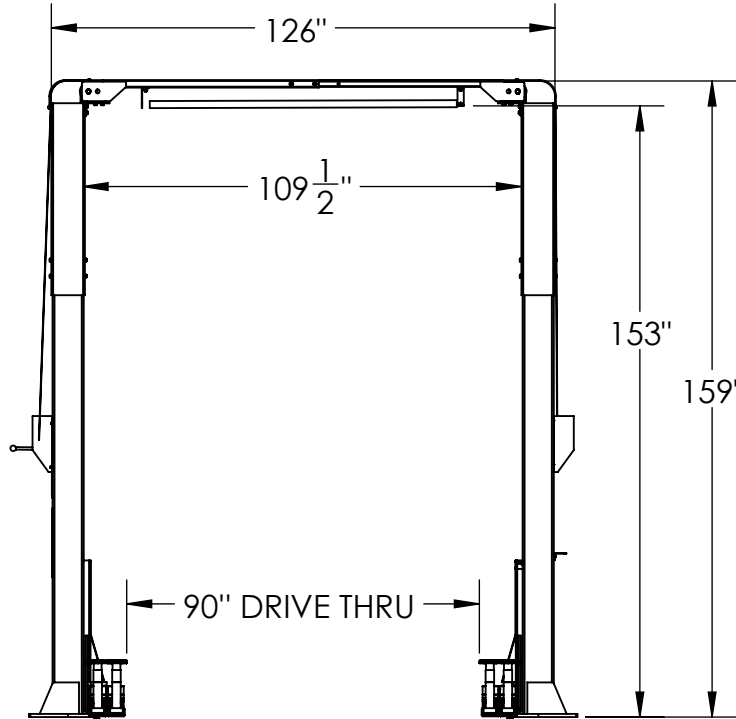

UNLESS OTHERWISE SPECIFIED:  
DIMENSIONS ARE IN [MM] INCHS

**TOLERANCES:**  
FRACTIONAL: ±[1.5] 1/16"  
ANGLE: MACH ±1/2° BEND ±1°  
X.X" (1 DECIMAL): ±[3] 0.1"  
X.XX" (2 DECIMAL): ±[1] 0.03"  
X.XXX" (3 DECIMAL): ±[0.5] 0.010"

**GEOMETRIC TOLERANCING PER:**  
ASME Y.14.5M-1994

MATERIAL

FINISH

DO NOT SCALE DRAWING



**PROPRIETARY AND CONFIDENTIAL**  
THE INFORMATION CONTAINED IN THIS DRAWING IS THE SOLE PROPERTY OF TOTAL AUTOMOTIVE LIFTING SOLUTIONS INC. (TLS). ANY REPRODUCTION IN PART OR AS A WHOLE WITHOUT THE WRITTEN PERMISSION OF TLS IS PROHIBITED.

NAME	DATE
DRAWN S.Z.	11/01/2013
CHECKED	
APPROVED	

**TOTAL AUTOMOTIVE LIFTING SOLUTIONS INC.**  
(905)847-1198 FAX (905)891-1214  
[www.TLSLifts.com](http://www.TLSLifts.com)

MODEL: TLS212MRx1

CAPACITY: 12,000LBS

SIZE	PART#	REV.
B	ALT. PART#	

SCALE: 1:48

SHEET 1 OF 1

8 7 6 5 4 3 2 1

12K 2 POST ASYMMETRIC