

8 7 6 5 4 3 2 1

D

C

B

A

D

C

B

A

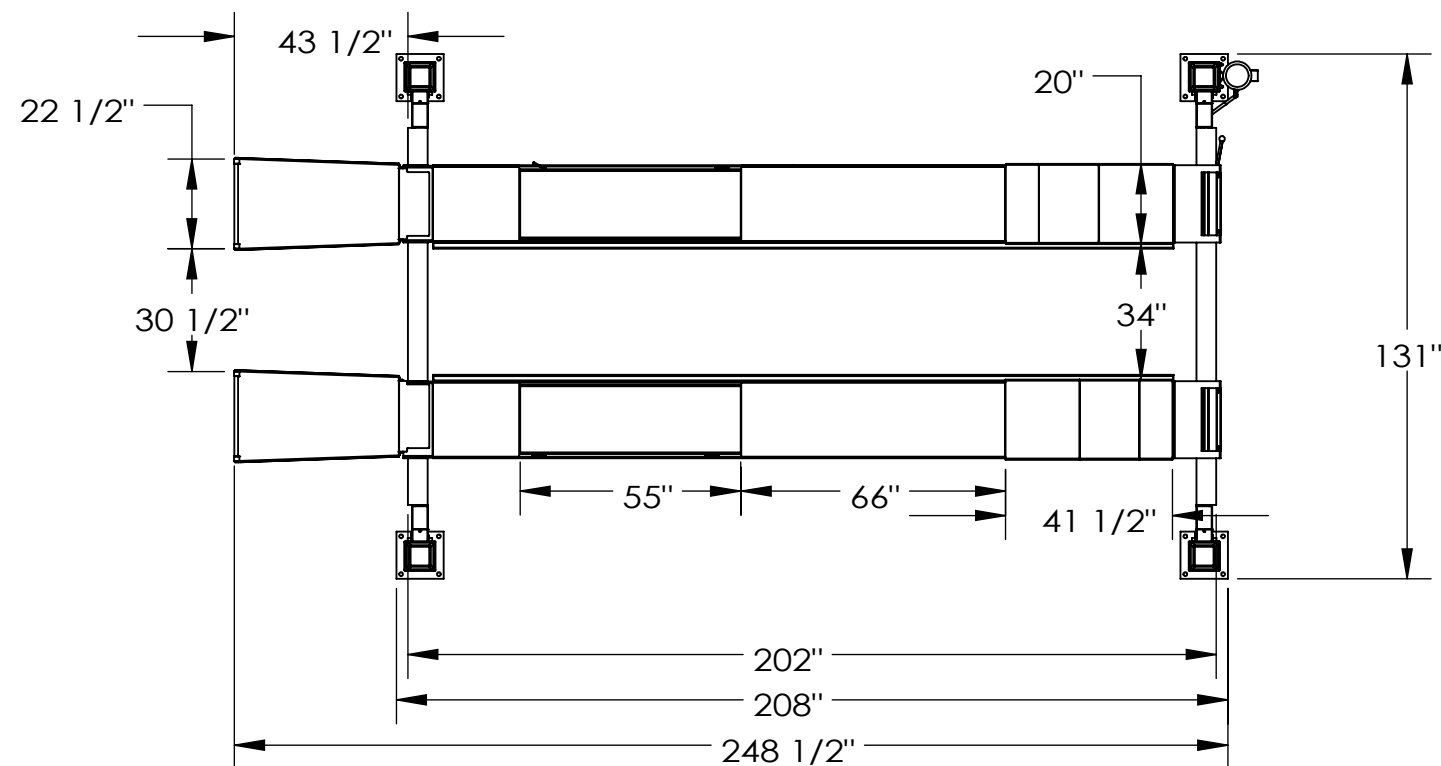
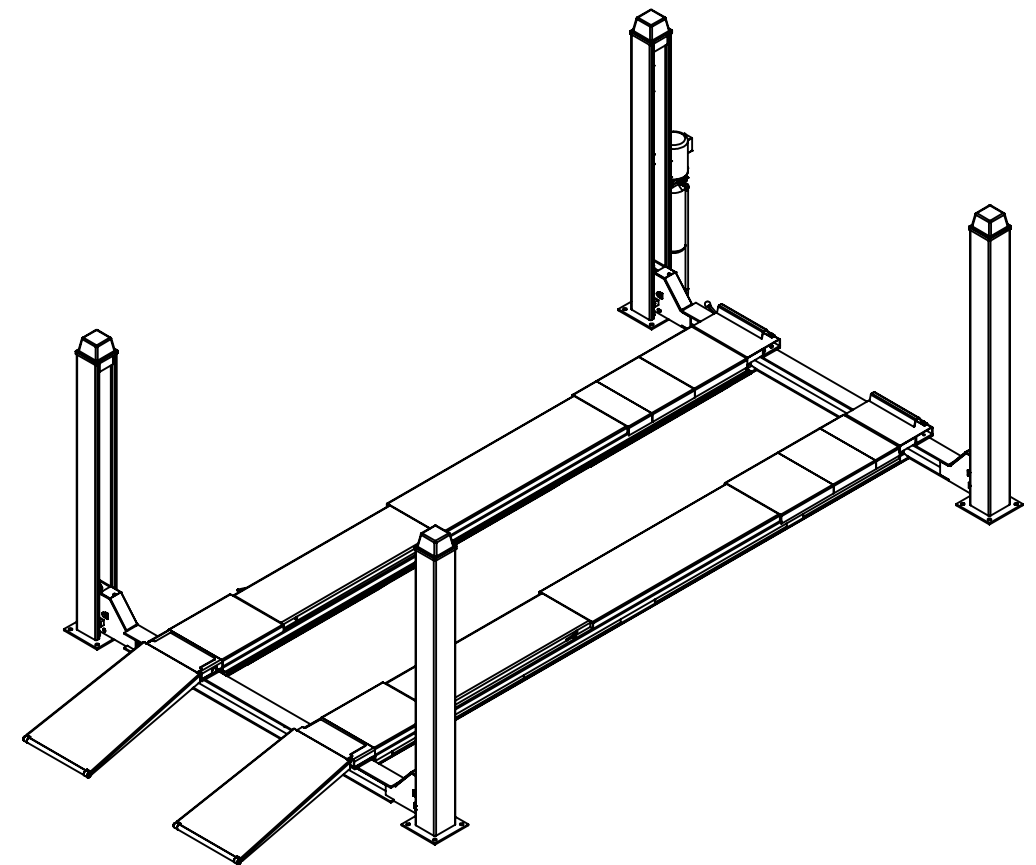
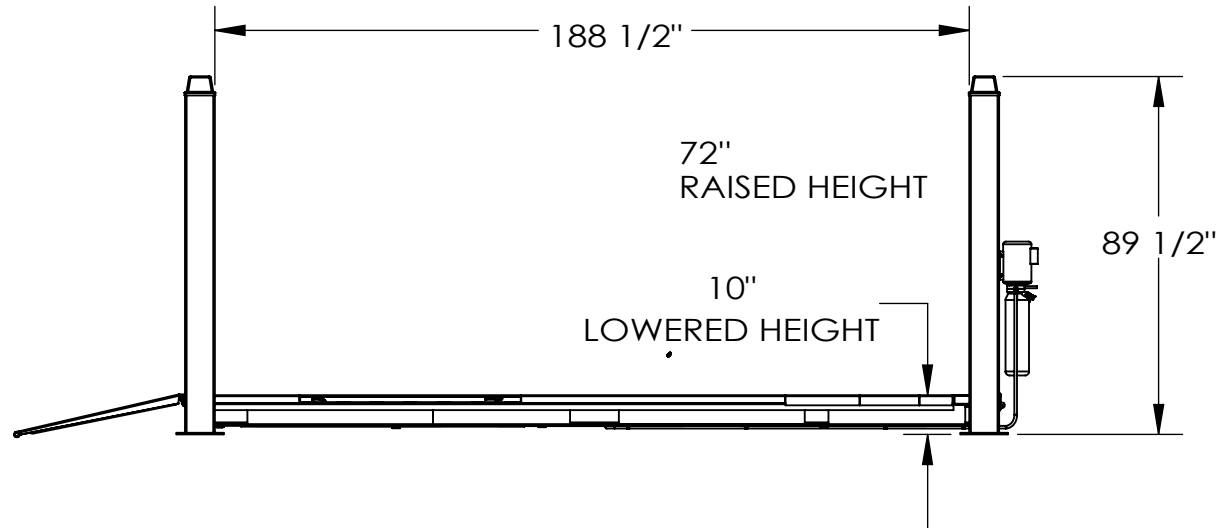

<p><b>UNLESS OTHERWISE SPECIFIED:</b> DIMENSIONS ARE IN [MM] INCHS</p>		 <p><b>PROPRIETARY AND CONFIDENTIAL</b> THE INFORMATION CONTAINED IN THIS DRAWING IS THE SOLE PROPERTY OF TOTAL AUTOMOTIVE LIFTING SOLUTIONS INC. (TLS). ANY REPRODUCTION IN PART OR AS A WHOLE WITHOUT THE WRITTEN PERMISSION OF TLS IS PROHIBITED.</p>		<p><b>TOTAL AUTOMOTIVE LIFTING SOLUTIONS INC.</b> (905)847-1198 FAX (905)891-1214 <a href="http://www.TLSLifts.com">www.TLSLifts.com</a></p>	
<p><b>TOLERANCES:</b> FRACTIONAL: ±[1.5] 1/16" ANGLE: MACH ±1/2° BEND ±1° X.X" (1 DECIMAL): ±[3] 0.1" X.XX" (2 DECIMAL): ±[1] 0.03" X.XXX" (3 DECIMAL): ±[0.5] 0.010" <b>GEOMETRIC TOLERANCING PER:</b> ASME Y.14.5M-1994</p>				<p>MODEL: TLS414ALCRx1</p>	
<p>MATERIAL</p>		<p>NAME</p>	<p>DATE</p>	<p>SIZE</p>	<p>PART#</p>
<p>FINISH</p>		<p>DRAWN</p>	<p>S.Z.</p>	<p>27/12/2012</p>	<p>REV.</p>
<p>DO NOT SCALE DRAWING</p>		<p>CHECKED</p>	<p>APPROVED</p>	<p>SCALE: 1:48</p>	<p>ALT. PART#</p>
				<p>SHEET 1 OF 1</p>	

8 7 6 5 4 3 2 1